

SV 210

Signal Splitter and Incremental Converter for Sine-Cosine Encoders

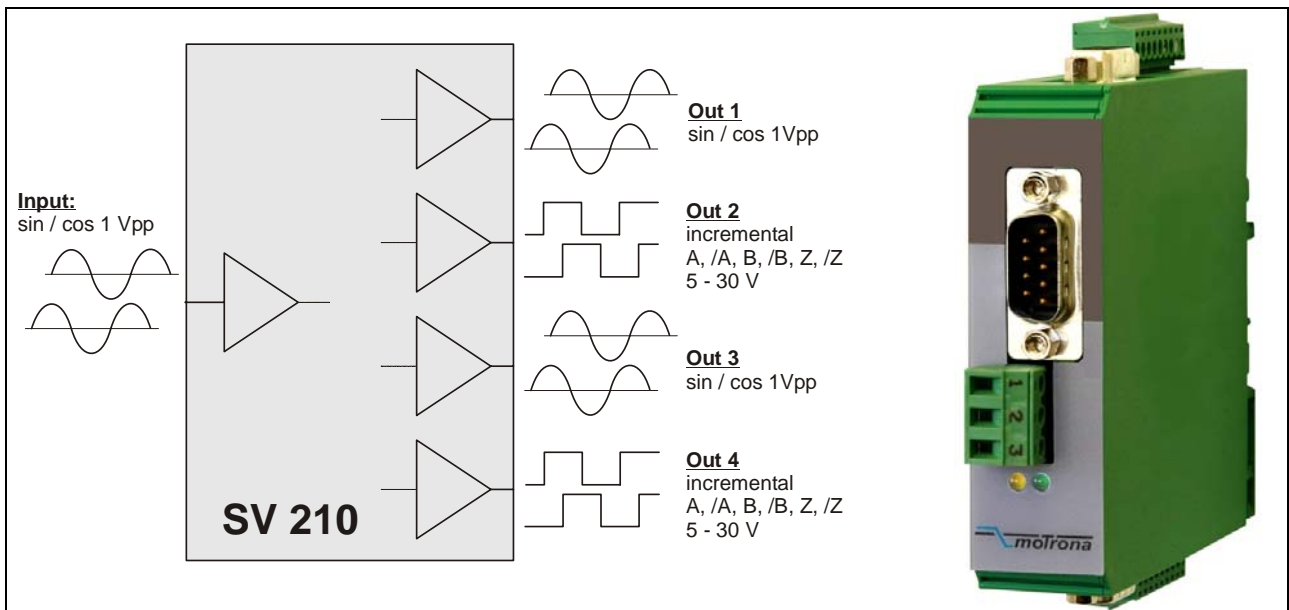

- Encoder inputs sin+, sin-, cos+, cos-, ref+, ref- with 1 Vpp format
- Two sine-cosine output channels with the same signal format
- Two incremental outputs, each with differential signal format A, /A, B, /B, Z, /Z , individually adjustable to either TTL/RS422 level or HTL (10-30 V) level
- Suitable for input frequencies up to 500 kHz
- 17 - 30 VDC power supply and auxiliary output 5 V or 24 V for encoder supply

Operating Instructions



Safety Instructions

- This manual is an essential part of the unit and contains important hints about function, correct handling and commissioning. Non-observance can result in damage to the unit or the machine or even in injury to persons using the equipment!
- The unit must only be installed, connected and activated by a qualified electrician
- It is a must to observe all general and also all country-specific and application-specific safety standards
- When this unit is used with applications where failure or maloperation could cause damage to a machine or hazard to the operating staff, it is indispensable to meet effective precautions in order to avoid such consequences
- Regarding installation, wiring, environmental conditions, screening of cables and earthing, you must follow the general standards of industrial automation industry
- - Errors and omissions excepted –



General instructions for cabling, screening and grounding can be found in the SUPPORT section of our website <http://www.motrona.com>

Version:	Description:
SV21001a_July 2010/af/hk	First edition

Table of Contents

1. Application.....	4
2. Connection Diagram	6
2.1. Power Supply (X6)	6
2.2. Connection of the Sine-Cosine Encoder (X5)	7
2.3. The Sine-Cosine Outputs (X1 und X3)	7
2.4. The Incremental Outputs (X2 und X4)	8
3. The Front LEDs	9
4. Dimensions	10
5. Technical Specifications	11

1. Application

The SV 210 encoder splitter has been designed for clean and trouble-free distribution of the output signals of sine-cosine type encoders to several target units. Since on the output site the unit provides both, sine-cosine outputs and incremental outputs, it is suitable for use with target units with either sine or incremental inputs.

On both sine output channels the same signal format is available as on the input site, including a reference impulse (if available on the input site). All sine-cosine signals use the differential 1 Vpp format which is most common with industrial sine-cosine encoders.

Current signals according to the 11 μ A standard are not supported by this unit.

The two incremental output channels at the same time supply square wave signals, namely one impulse per each sine period and one index pulse per each reference signal on the input side. At any time the differential signals A, /A, B, /B, Z /Z are available and the output level is settable to either TTL (5 V) or HTL (10 - 30 V) level, separately for each output channel.

The diagram below explains the correlation between sine signals and incremental signals.

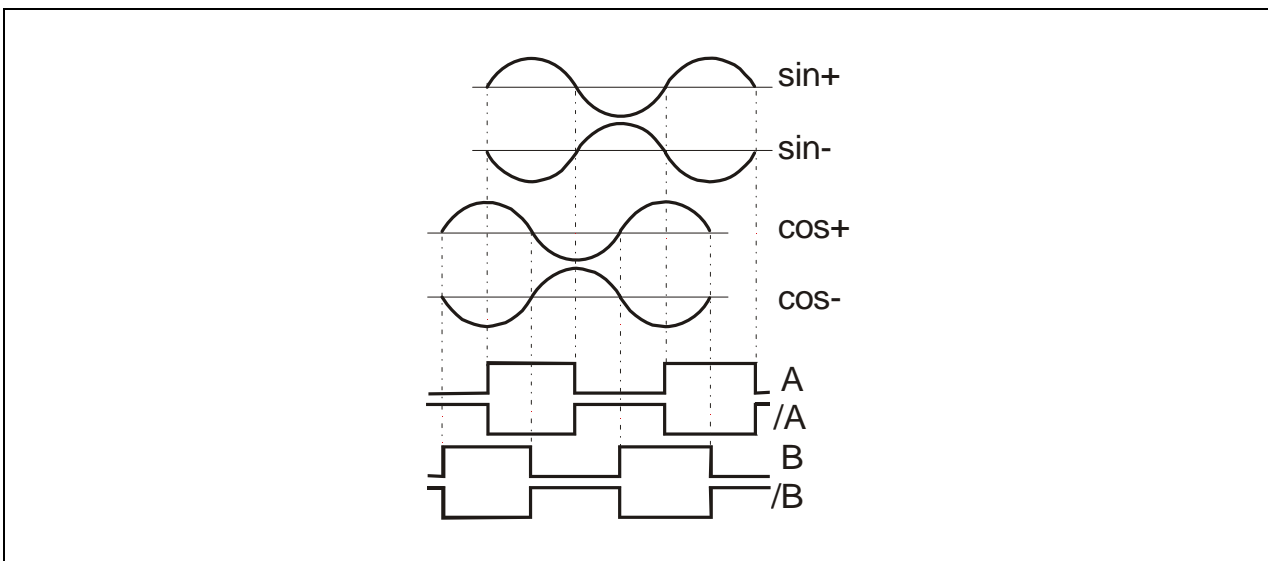

For interpolation of the sine waves to a higher number of incremental impulses (e.g. 50 increments per sine period) please refer to our Sine-Cosine Interpolator type SI251

Typical application example of the SV 210 signal splitter:

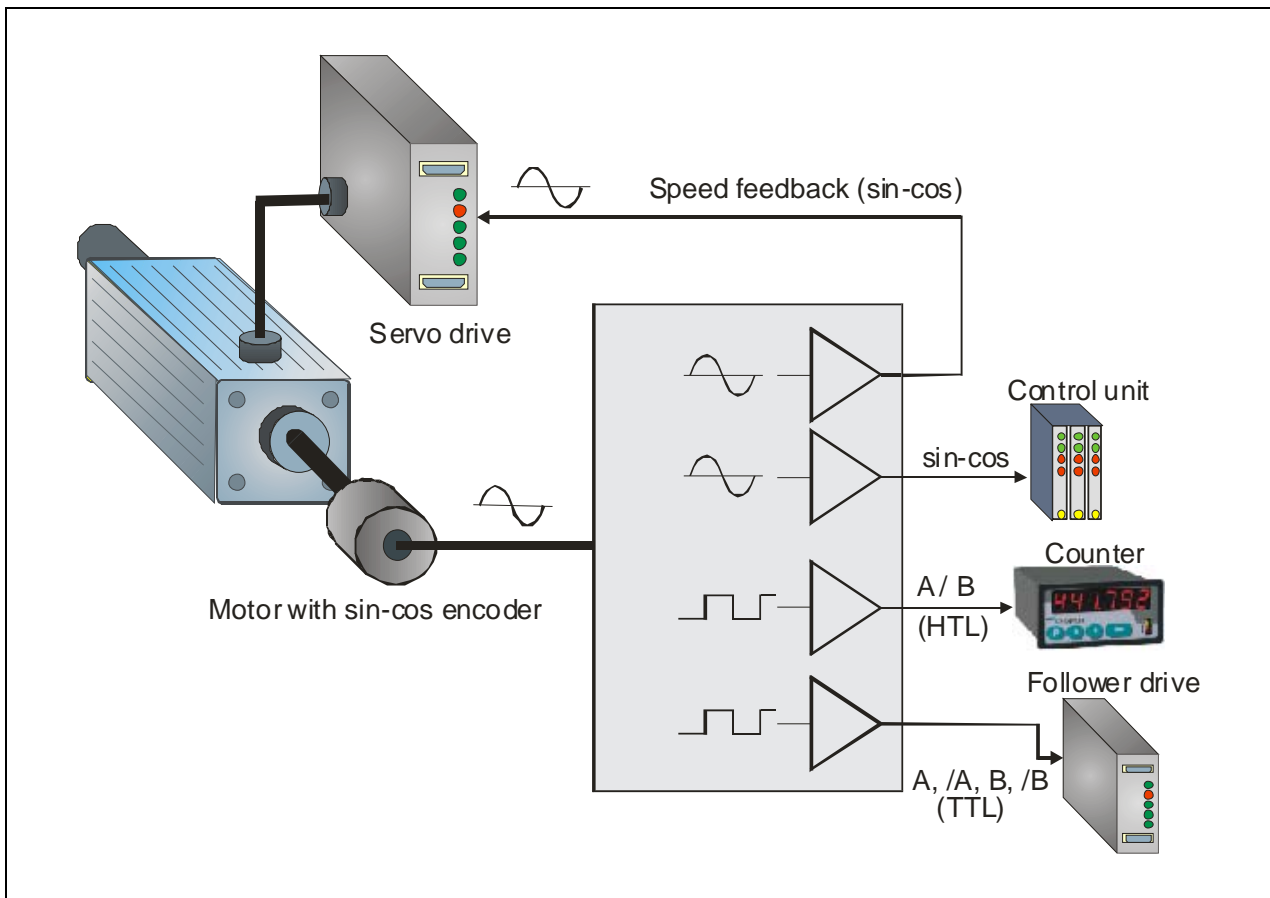

2. Connection Diagram

For wiring of the sinusoidal signals the unit provides 3 Sub-D-9 connectors (X1, X3, and X5). For all other connections 3 screw terminal strips (X2, X4, and X6).

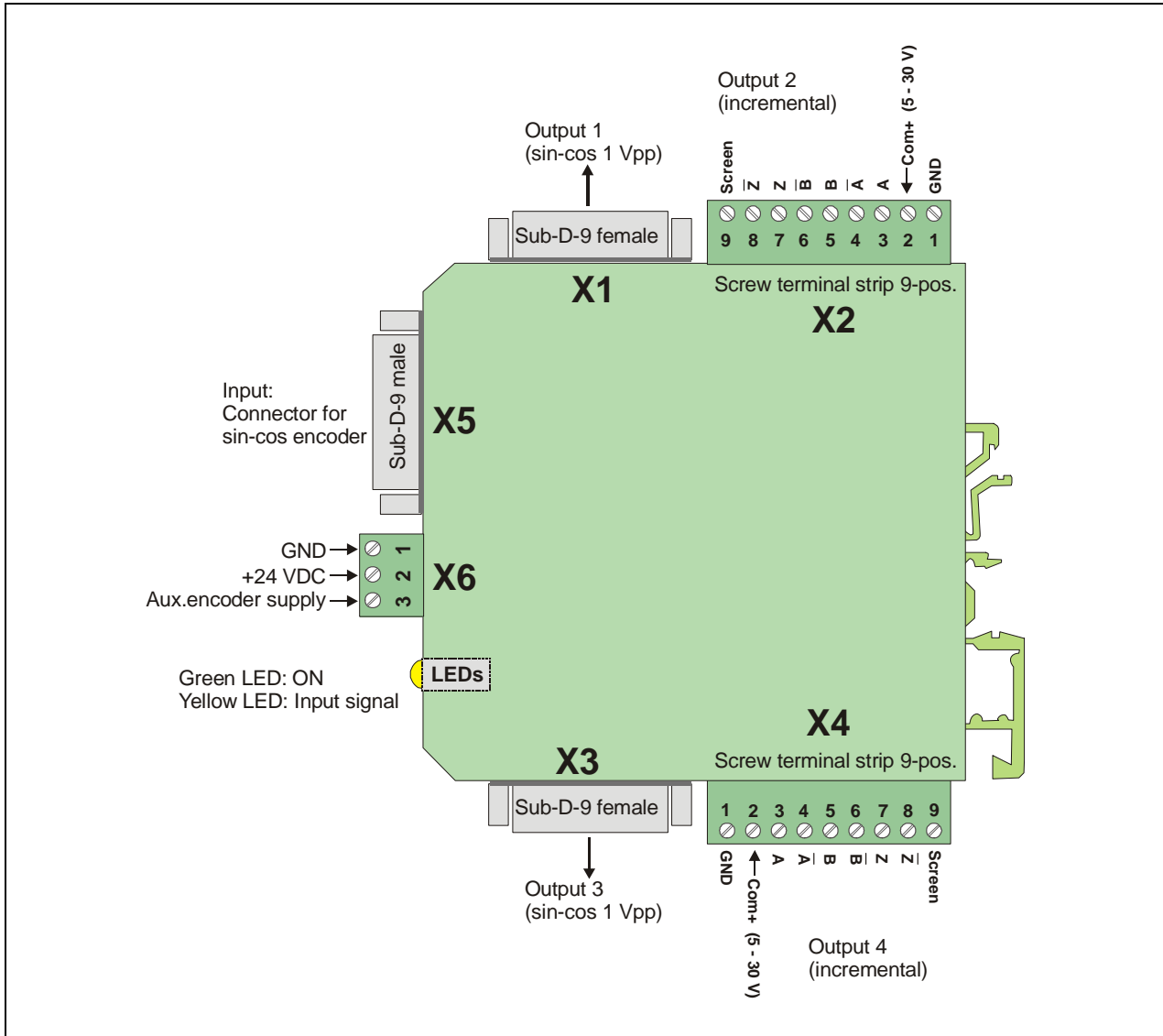

2.1. Power Supply (X6)

The unit operates from a DC power from 17 to 30 volts which must be applied to the front terminals X6/1 (-) and X6/2 (+).

With unloaded state the current consumption is about 70 mA (encoder supply line and output channels unconnected).

Terminal X6/3 selects the level of the auxiliary encoder supply output (5 V or 24 V). More details are explained under section 2.2 (Encoder connection).

2.2. Connection of the Sine-Cosine Encoder (X5)

The encoder can be connected via the front Sub-D-9 connector marked X5 (male connector on unit side, female connector on the encoder cable). Only encoders with differential sine-cosine signals of 1 Vpp can be used (0.8 Vpp - 1.2 Vpp). At any time the signals sin+/sin- and cos+/cos- must be available. Where an additional reference marker pulse is used, also the signals ref+/ref- must be applied.

Pins 4 (+) and 5(-) of the Sub-D-connector provide an auxiliary power output for the encoder supply. When terminal 3 of the front X6 connector is unconnected, the aux. output voltage is automatically about 5.2 volts (max. 150 mA). Where the encoder requires another supply voltage (e.g. 24 volts), an appropriate voltage can be applied remotely to terminal X6/3.

Please note that the metallic housing of the Sub-D input connector is internally connected to the common GND potential of the unit.

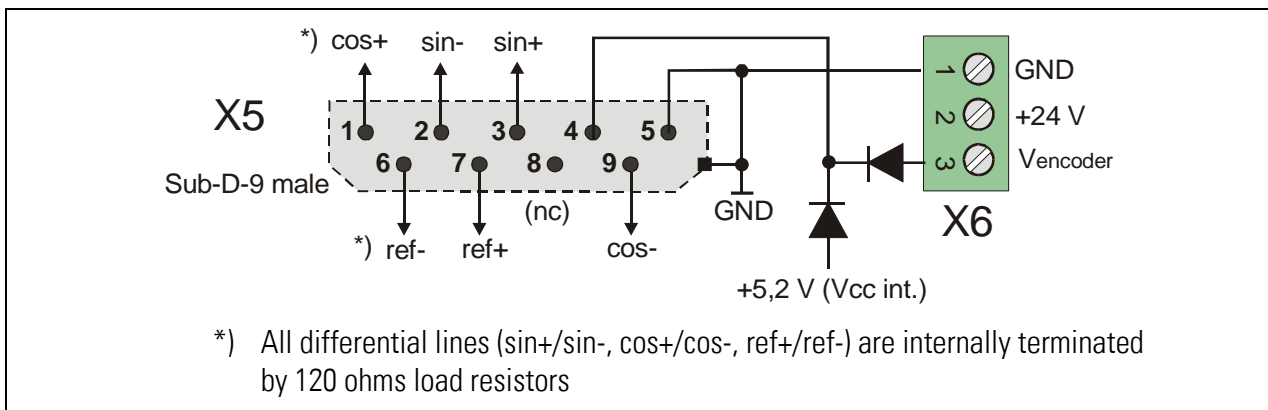

2.3. The Sine-Cosine Outputs (X1 und X3)

These two Sub-D-outputs provide an image of the sine-cosine input signals, however with a fixed offset voltage of 2.5 volts with respect to GND. This allows a clean and trouble-free distribution of the input signal to two target units.

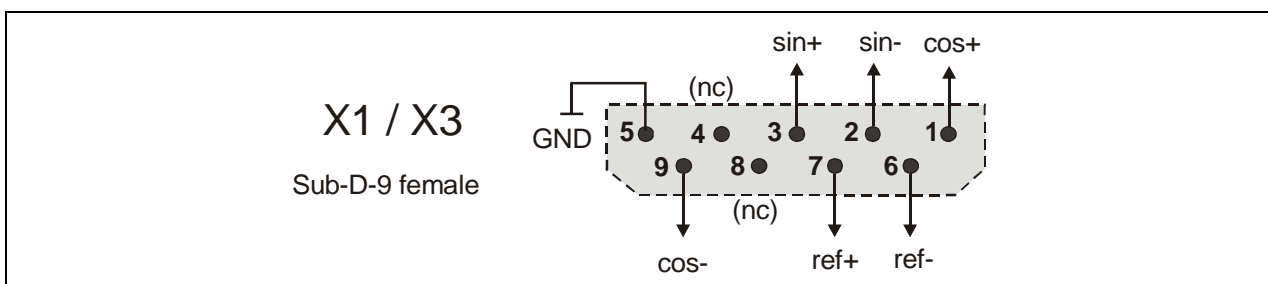

- It is mandatory to use cables with pairwise twisted wires for all sinusoidal signals sin+/sin-, cos+/cos- and ref+/ref-.
- For trouble-free signal transmission the target unit must provide terminating resistors at the end of the signal line (in each case 120 ohms between signal+ and signal-)
- Since on the inputs the unit already uses in-built termination resistors, no further measures must be taken on the encoder side.

2.4. The Incremental Outputs (X2 und X4)

On the terminal strips X2 and X4 the encoder information is available with a differential square wave format. All incremental outputs use push-pull drivers. When position 2 (Com+) of the corresponding terminal strip is unconnected, the output level is automatically adapted to TTL / RS422 format. As soon as terminal position 2 receives any external voltage >5.5 volts, automatically this voltage will determine the output swing. Consequently each of the two incremental outputs can operate with its own specific TTL or HTL level.

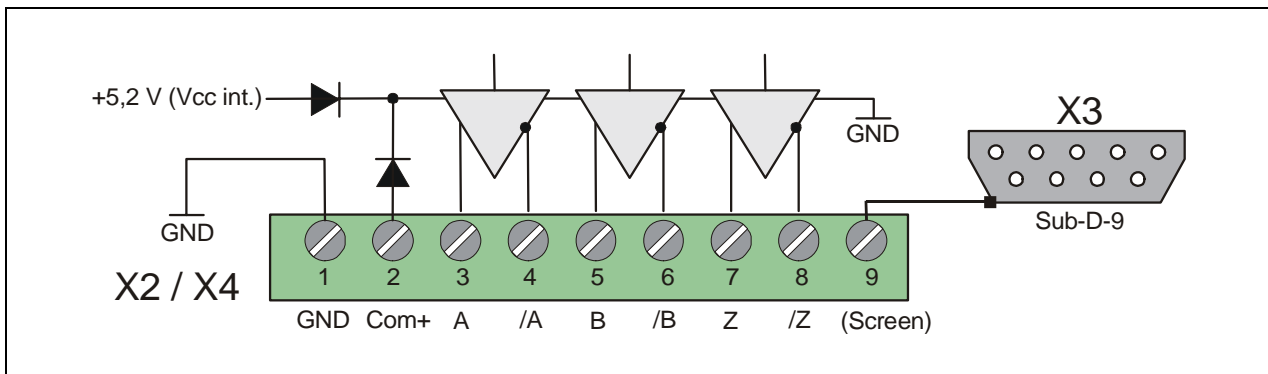

Positions 9 of the terminal strips X2 and X4 are in each case galvanically connected to the metal housing of the adjacent Sub-D connector (located on the same side of the housing)

It is recommendable to connect the cable shield directly to the metal housing of the associated counterpart connector, and to wire terminal position 9 to earth or ground potential. This ensures that the cable shield is earthed / grounded correctly.

3. The Front LEDs

The green LED is lit whenever the power supply of the unit is on.

The yellow Led indicates the presence of encoder input signals. With slow motion, the LED will blink with every input impulse. With higher speeds the blinking will pass over into a continuous glowing with reduced brightness.

4. Dimensions

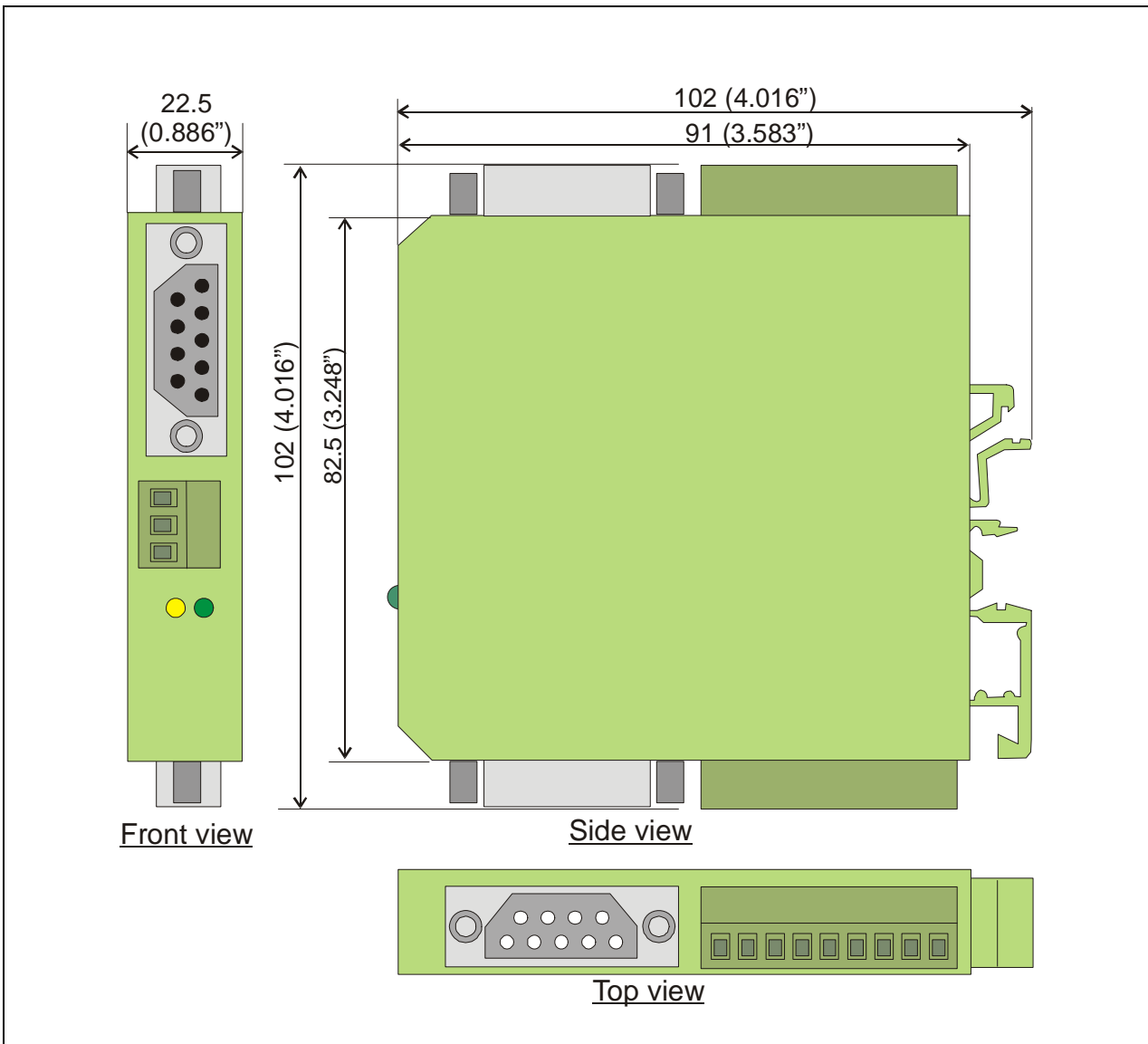

5. Technical Specifications

Power supply V_{in}	:	17 V - 30 VDC
Supply current	:	approx. 70 mA (unloaded)
Aux. encoder power output	:	5,2V / 150 mA (or according to remote feed-in)
Max. frequency	:	500 kHz
Signal inputs (Terminating resistors 3 x 120 ohms inbuilt)	:	6 symmetric differential sin/cos - inputs (sin+, sin-, cos+, cos-, ref+, ref-), Signal level 0,8 Vpp - 1,2 Vpp, Signal offset approx. 2 - 3 V to GND
Signal outputs sin-cos (Termination resistors must be available on the target unit side)	:	2 x 6 symmetric differential outputs (each time sin+, sin-, cos+, cos-, ref+, ref-), Signal level 0,8 Vpp - 1,2 Vpp, Signal offset 2,5 V to GND
Square wave outputs	:	2 x 6 incremental push-pull outputs (each time A, /A, B, /B, Z, /Z), Output level individually adaptable to TTL (5 V) or HTL (max. 30 V)), max. 30 mA per channel (short-circuit proof)
Propagation delay time	:	approx. 200 nsec.
Ambient temperature	:	Operation: 0° - +45° C (+32° - +113° F) Storage: -25° - +70° C (-13° - +158° F)
Weight	:	approx. 100 g
Conformity and standards	:	EMC 2004/108/EC: EN 61000-6-2 EN 61000-6-3