

# GV 480 / GV 481

## Impulse Splitters for Incremental Encoders with All-Around Potential Separation of All Circuits

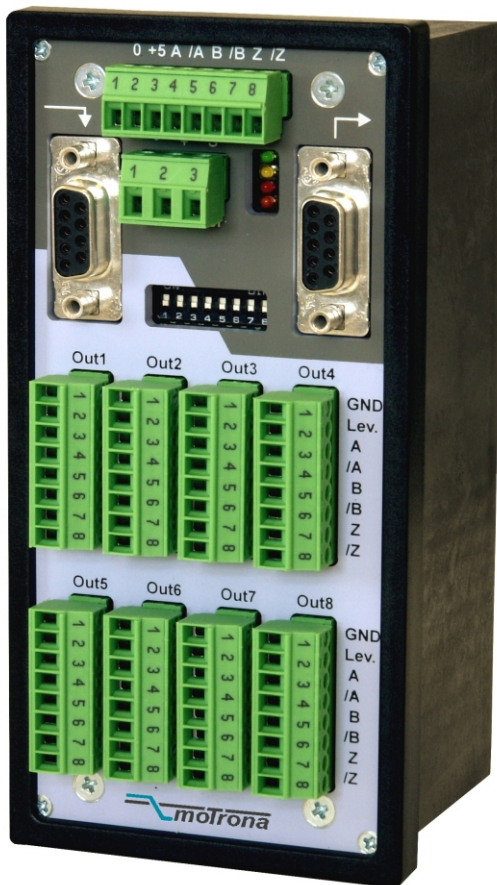

GV 480: Splitter with 8 Output Channels



GV 481: Splitter with 4 Output Channels

## Operating Instructions



## Safety Instructions

- This manual is an essential part of the unit and contains important hints about function, correct handling and commissioning. Non-observance can result in damage to the unit or the machine, or even in injury to persons using the equipment !
- The unit must only be installed, connected and activated by a qualified electrician
- It is a must to observe all general and also all country-specific and application-specific safety standards
- When this unit is used with applications where failure or maloperation could cause damage to a machine or hazard to the operating staff, it is indispensable to meet effective precautions in order to avoid such consequences
- Regarding installation, wiring, environmental conditions, screening of cables and earthing, you must follow the general standards of industrial automation industry
- - Errors and omissions excepted –

Version:	Description
GV48001a/Jan09/af_hk	Original edition

# Table of Contents

<b>1.</b>	<b>Introduction and Block Diagram</b>	<b>4</b>
<b>2.</b>	<b>Electrical Connections and LED Function</b>	<b>6</b>
2.1.	Power Supply and LEDs	6
2.2.	Auxiliary Encoder Supply	6
2.3.	Impulse Inputs	7
2.3.1.	Encoders with differential output (valid for output levels TTL/ 5 volts and for HTL / 10-30 volts as well)	7
2.3.2.	Encoders with single-ended output, without inverted signals (acceptable only with HTL level 10 - 30 volts)	7
2.3.3.	Differential signals from an encoder simulation (TTL level with remarkable noise)	7
2.3.4.	Differential signals for encoder channels A and B, but single-ended marker pulse from proximity switch or photocell	8
2.4.	The Outputs	9
2.5.	Cascading of Several Units and Encoder Select Function	9
<b>3.</b>	<b>Technical Specifications</b>	<b>11</b>
<b>4.</b>	<b>Dimensions</b>	<b>12</b>

# 1. Introduction and Block Diagram

GV480 and GV481 represent a series of incremental encoder splitters with a most compact, space-saving design and with most versatile technical features. Both models are fully identical except for the number of output channels (4 or 8 channels)

Compared to the well-known products GV470 und GV471 the GV480/481 models differ in a total galvanic separation between inputs, the power supply and all outputs one against each other. This feature, in general, can be most advantageous with impulse distribution among expanded production lines with adverse conditions of EMC / grounding / potential shift etc.

The encoder input is switch-selectable for operation with either standard RS422 signals, with differential TTL or HTL signals or with single-ended HTL encoder signals. All encoder outputs provide fully isolated push-pull drivers with individual assignment of the output level for each of the output channels.

Separate cascading ports provide easy cascading of multiple units without loss of regular encoder outputs. Furthermore, cascaded units allow selection and commutation between different encoder inputs.

The adjoining block diagram clearly explains the principle of operation and the potential conditions between all circuits. For simplification the illustration shows only two of the outputs, since all other outputs are fully identical.

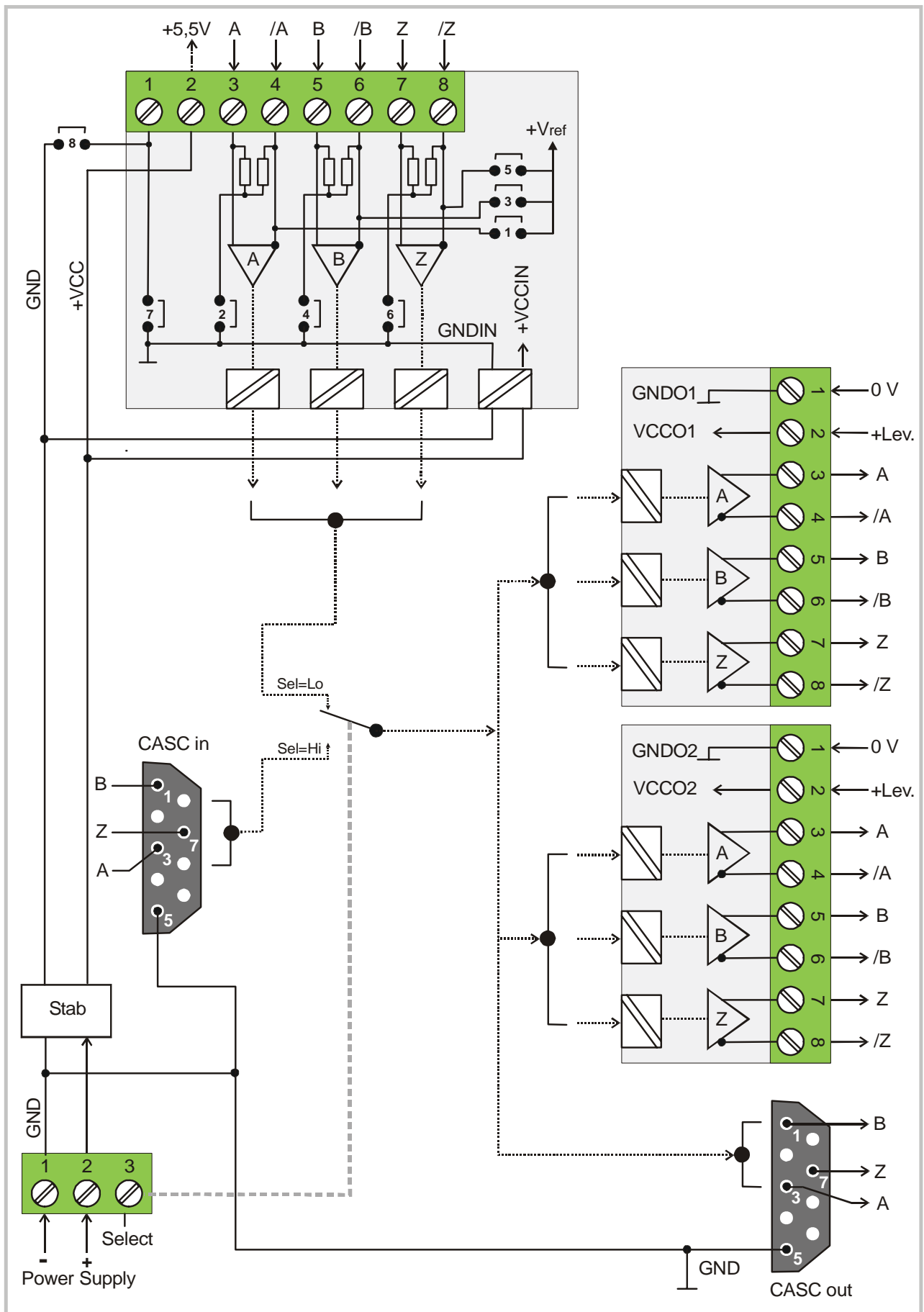

## 2. Electrical Connections and LED Function

### 2.1. Power Supply and LEDs

The unit provides a 3-position screw terminal strip for supply from a 10 – 30 volts DC power unit. The current consumption is approx. 40 mA (no-load operation).

The “Select” input terminal provides selection of the desired source encoder. Details will be described later.

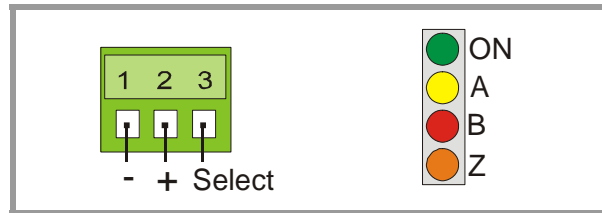

The upper LED (green) signals that power is applied to the unit.

The lower LEDs (yellow, red, orange) signal the actual logical states of the input channels A, B and Z. With very low input frequencies it is possible to visually check the input pulses, the phase displacement A/B and the index pulse function of an encoder.

### 2.2. Auxiliary Encoder Supply

The input encoder must be connected to the 8-position input terminal strip.

Depending on the application and the encoder type, one of the following options will apply for the power supply of the encoder:

- Remote supply via separate source
- Same power source that also supplies the GV480 unit (10 - 30 VDC)
- Use of the built-in auxiliary 5.5 volts power supply (terminal 2 of the input connector)



- When the built-in 5,5 volts power should be used to supply the encoder, position 8 of the DIL switch has to be set to "ON".
- This action will suspend the galvanic separation between input and the unit power supply. However, full isolation to all outputs will be maintained

## 2.3. Impulse Inputs

The 8-position DIL switch on the front side provides setting of the desired signal formats and levels. These settings are separately for each of the channels A / B / Z (see block diagram). For simplification, a short form of the four most common applications is shown below, with the encoder supply omitted:

### 2.3.1. Encoders with differential output

(valid for output levels TTL/ 5 volts and for HTL / 10-30 volts as well)

Terminal Connections	DIL Switch Setting
<p>1 2 3 4 5 6 7 8 0V A /A B /B Z /Z</p>	<p>A B Z ON 1 2 3 4 5 6 7 8</p>

### 2.3.2. Encoders with single-ended output, without inverted signals

(acceptable only with HTL level 10 - 30 volts)

Terminal Connections	DIL Switch Setting
<p>1 2 3 4 5 6 7 8 0V A B Z</p>	<p>ON 1 2 3 4 5 6 7 8</p>

### 2.3.3. Differential signals from an encoder simulation

(TTL level with remarkable noise)

Basically, signals generated by the encoder simulation of a drive can be treated similarly to a TTL encoder as described under 2.3.1. If however there should come up problems with the quality of the output signals (caused by awkward environmental conditions), the following mode of connection may remarkably improve the situation. This is a pure differential operation with fully floating potential, without any reference point.

It is important to leave terminal 1 unconnected.

Terminal Connections	DIL Switch Setting
<p>1 2 3 4 5 6 7 8 A /A B /B Z /Z</p>	<p>ON 1 2 3 4 5 6 7 8</p>

### 2.3.4. Differential signals for encoder channels A and B, but single-ended marker pulse from proximity switch or photocell

Besides the most common standard configurations shown before, the unit allows setting of any other input configuration (e.g. differential encoder inputs on channels A, /A, B, /B, but single-ended index signal on input Z (from a proximity switch, photocell or similar)

The block diagram shows which of the DIL switch positions is responsible for each of the channels. It is easy to figure out other settings from the examples given in this manual.

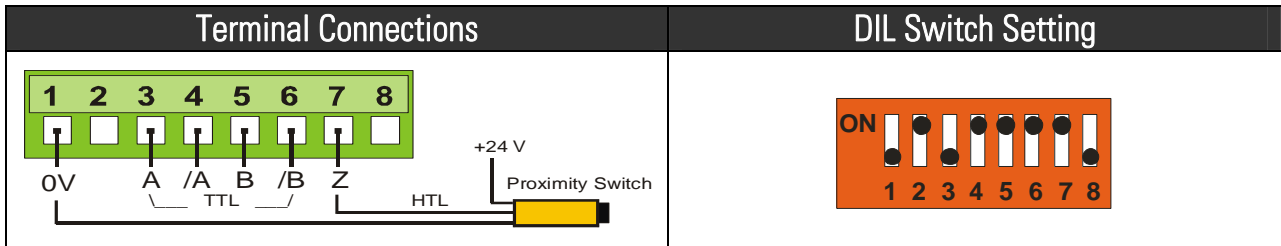



- The normal encoder input terminal will not accept any single-ended signals with TTL level, i.e. single-ended signals have to provide HTL level
- Nevertheless, in special cases, the cascading inputs of the unit can be used to apply single-ended TTL signals (CMOS, Low <0.8 V, High >3.5 V). This however assumes proper EMC conditions and environment as well as short cables on the input side.
- The input terminal strip provides a codification to avoid accidental mix-up with the other connectors of the unit

## 2.4. The Outputs

All outputs always provide the non-inverted and the inverted signals, even when on the input side the inverted signals are not available. All outputs are fully isolated one against each other and against the input and the power supply.

All output connectors use the same connector codification and may be interchanged among each other, since the electrical circuit of all 8 channels is the same and only the voltage applied to the "Level" terminal of the mating connector determines the output level.

On terminal 1 (0V) and terminal 2 (+Lev.) a remote voltage has to be applied to each output stage, which at the same time also determines the signal level on the corresponding output. The permitted range is from 5 to 30 volts and the signal swing will be about 0.7 volts less than the remote voltage applied. All output lines are permanently short-circuit-proof and the maximum output current is 30 mA per line.

The terminal assignment can be found in the block diagram and is also printed to the front plate of the unit. All output terminal strips have the same codification, since it is fully unimportant to which of the outputs a terminal strip is connected (only the external voltage applied to the "Lev." input of the mating connector is responsible for the output level).

## 2.5. Cascading of Several Units and Encoder Select Function

The unit can be cascaded very easily to any number of output channels, without loss of regular encoder outputs. For cascading, pins 1, 3, 5 and 7 of the cascading output of the first unit must be connected to the corresponding pins of the cascading input of the follower unit.

**An appropriate ribbon cable connection is available under motrona part # FK470**

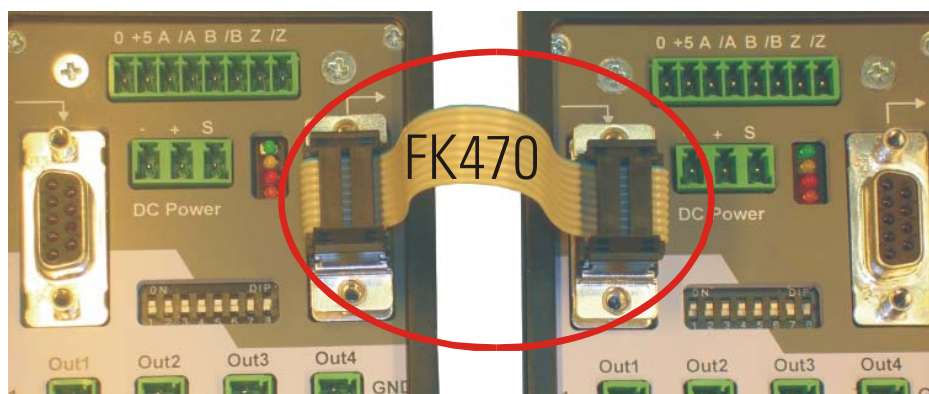

Cascading lines use the same common GND potential as the power supply of the unit. This however does not mean any disadvantage in terms of galvanic isolation etc. since cascading units are always mounted alongside and are also supplied from the same power source.

Cascaded units allow selection of the active source encoder via the encoder select input on the 3-position power connector (see also block diagram):

**LOW** (or open): outputs refer to the encoder input of the same unit

**HIGH** (10 – 30 volts): outputs refer to the encoder input of the preceding unit

It is possible at any time to switch over from one to the other source encoder during operation.



Where only one common encoder is used, the select input of the first unit remains unconnected. The select inputs of all follower units are advantageously connected to the +pole of the power supply located next to the select input

### 3. Technical Specifications

Power supply	:	10 – 30 VDC	
Power consumption: (without encoder supply)	:	ca. 40 mA	
Aux. encoder supply	:	built-in 5.5 volts, 200 mA *)	
Max. frequency	:	TTL (differential) and RS422: (diff. voltage >0,5V)	500 kHz
		HTL (10 - 30 V):	200 kHz
Input level with HTL single-ended (no inverted signal available)	:	Low: < 4 V,	High: > 10 V
Input level "Select" Input	:	Low: < 4 V,	High: > 10 V
Cascading input	:	A, B, Z, Pegel 5 V ( CMOS, Low <0.8 V, High >3.5 V )	
Outputs	:	Push-pull stages 5 – 30 V / 30 mA (short-circuit-proof)	
Propagation delay time	:	400 nsec.	
Mounting	:	Standard DIN rail	
Weight	:	approx. 400 g	
Temperature range	:	Operation: 0 – 60 °C (+32 - +140 °F) Storage: -25 - +75° (-13 - +167°F)	
Conformity and standards	:	EMC 2004/108/EC:	EN 61000-6-2 EN 61000-6-3

\*) Please observe galvanic connection to the power supply

## 4. Dimensions

