

BY340 and BY641

High Performance Low Cost Synchronous Controllers



- Precision angular synchronization and speed ratio control
- High accuracy due to high feedback frequency range (300 kHz with TTL encoders and 200 kHz with HTL encoders)
- Full remote phase control by Index pulse operation, Trim functions etc.
- 4 programmable alert outputs
- Most compact unit including operator panel for direct access and RS232 interface for remote access
- PROFIBUS DP interface available (option)

Operating Instructions



Safety Instructions

- This manual is an essential part of the unit and contains important hints about function, correct handling and commissioning. Non-observance can result in damage to the unit or the machine or even in injury to persons using the equipment!
- The unit must only be installed, connected and activated by a qualified electrician
- It is a must to observe all general and also all country-specific and application-specific safety standards
- When this unit is used with applications where failure or maloperation could cause damage to a machine or hazard to the operating staff, it is indispensable to meet effective precautions in order to avoid such consequences
- Regarding installation, wiring, environmental conditions, screening of cables and earthing, you must follow the general standards of industrial automation industry
- - Errors and omissions excepted –

Version:	Description:
BY34002a/April 07/mb/hk	First edition
BY34002b/Juli 07/mb/hk	Small corrections and supplements

Table of Contents

1.	Available Models	4
2.	Introduction	5
3.	Electrical Connections	6
3.1.	Power Supply	8
3.2.	Auxiliary Outputs for Encoder Supply.....	8
3.3.	Impulse Inputs for Incremental Encoders	8
3.4.	Control Inputs Cont.1 – Cont.4	9
3.5.	Switching Outputs K1 – K4.....	9
3.6.	Serial Interface	9
3.7.	Analogue Outputs	9
4.	Principle of Operation	10
4.1.	Synchronization.....	10
4.2.	Mechanical Phase and Position Considerations	11
5.	Operating Modes	12
6.	Keypad Operation	13
6.1.	Normal Operation	13
6.2.	General Setup Procedure.....	13
6.3.	Direct Fast Access to Speed Ratio Setting	14
6.4.	Change of Parameter Values on the Numeric Level	15
6.5.	Code Protection against Unauthorized Keypad Access	16
6.6.	Return from the Programming Levels and Time-Out Function	16
6.7.	Reset all Parameters to Factory Default Values	16
7.	Menu Structure and Description of Parameters	17
7.1.	Summary of the Menu	17
7.2.	Description of the Parameters.....	19
8.	Description of Commands and Outputs	30
8.1.	Commands	30
8.2.	Outputs.....	31
9.	Steps for Commissioning	32
9.1.	Running the Adjust menu	33
9.2.	Set Directions of Rotation	34
9.3.	Tuning the Analogue Output.....	34
9.4.	Setting of the Proportional Gain.....	35
9.5.	Hints for final operation.....	35
10.	Appendix for model BY 641	37
10.1.	Relay Outputs.....	37
10.2.	Front Thumbwheel Switches.....	37
11.	Specifications and Dimensions	38

1. Available Models

The two models as shown below are available. Both models are fully similar in terms of function and performance; however there is some difference with the size, the alert outputs and the speed ratio setting.

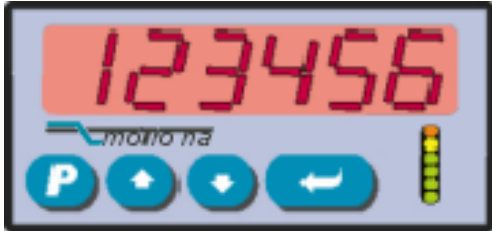
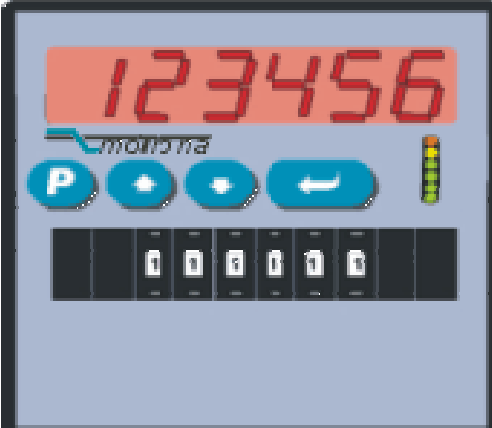
 The image shows the BY340 control panel. It features a red LED display showing the number '123456'. Below the display is the 'motrona' logo. The panel includes a 'P' button, two arrow buttons (up and down), and a left arrow button. A vertical status indicator with five yellow LEDs is on the right side.	<p>BY340:</p> <ul style="list-style-type: none">▪ Front size 96 x 48 mm (3.780'' x 1.890'')▪ Speed ratio setting by keypad▪ Analogue output 14 bits▪ 4 power transistor outputs (alert)
 The image shows the BY641 control panel. It features a red LED display showing the number '123456'. Below the display is the 'motrona' logo. The panel includes a 'P' button, two arrow buttons (up and down), and a left arrow button. Below these buttons is a row of six thumbwheel switches. A vertical status indicator with five yellow LEDs is on the right side.	<p>BY641:</p> <ul style="list-style-type: none">▪ Front size 96 x 96 mm (3.780'' x 3.780'')▪ Speed ratio setting by keypad or by front thumbwheel switches▪ Analogue output 14 bits▪ 4 power transistor outputs (alert) and 4 relay outputs (alert)

Both models are suitable for front panel or operator desk mounting, by means of the included mounting clamps.

Where you desire to mount the units on DIN rails inside a cabinet, please refer to the mounting brackets type SM 300 and SM 600 available as accessories.

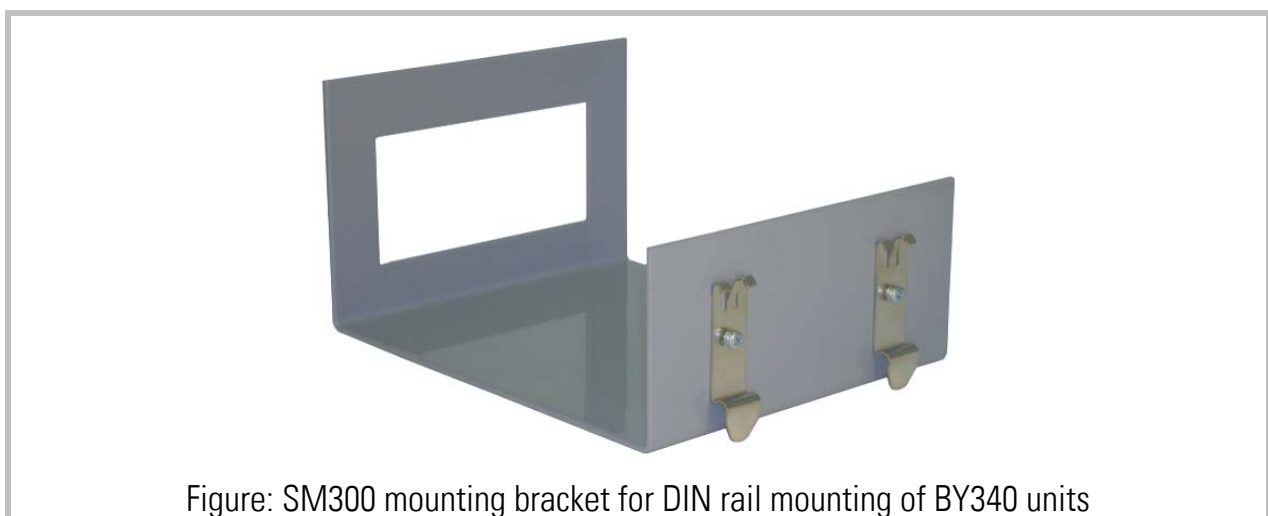

Figure: SM300 mounting bracket for DIN rail mounting of BY340 units

2. Introduction

The BY340 / BY641 units are suitable to operate as electronic synchronous controllers with speed-variable drives of any kind and any size, provided they dispose of an analogue input to set the speed. The operation is based on a Master / Slave principle.

The Master could basically be any moving part of a machine, provided there is a quadrature incremental encoder signal available from the Master motion. The Slave would typically be a speed-variable drive like an Inverter Drive or Servo Drive or DC Drive, but could also be a hydraulic system with a servo valve or similar. In any case a quadrature feedback signal is also necessary from the Slave.

The subsequent drawing shows an example of speed synchronization between two belts, including automatic position adjustment by means of index sensors (optional).

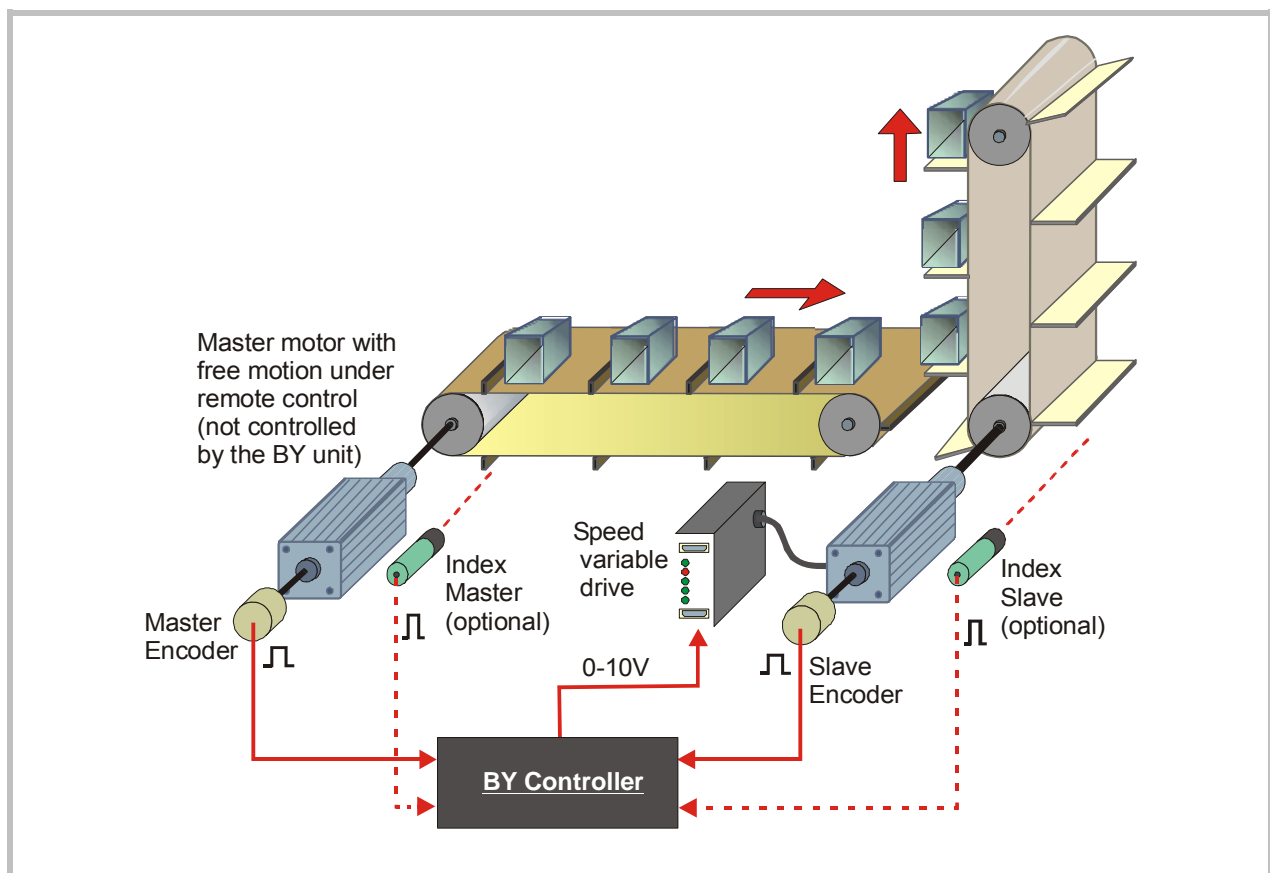

- This manual first provides all basic instructions for operation of model BY340
- For operation of relays and thumbwheels with model BY 641 see appendix
- For PC setup our "OS32" software is available on the CD included to delivery, or on our homepage www.motrona.com
- For communication by PLC or IPC or by a remote operator terminal, please observe the serial protocol details described in our separate manual "Serpro".
- PROFIBUS communication is possible with use of our gateway PB251.

3. Electrical Connections

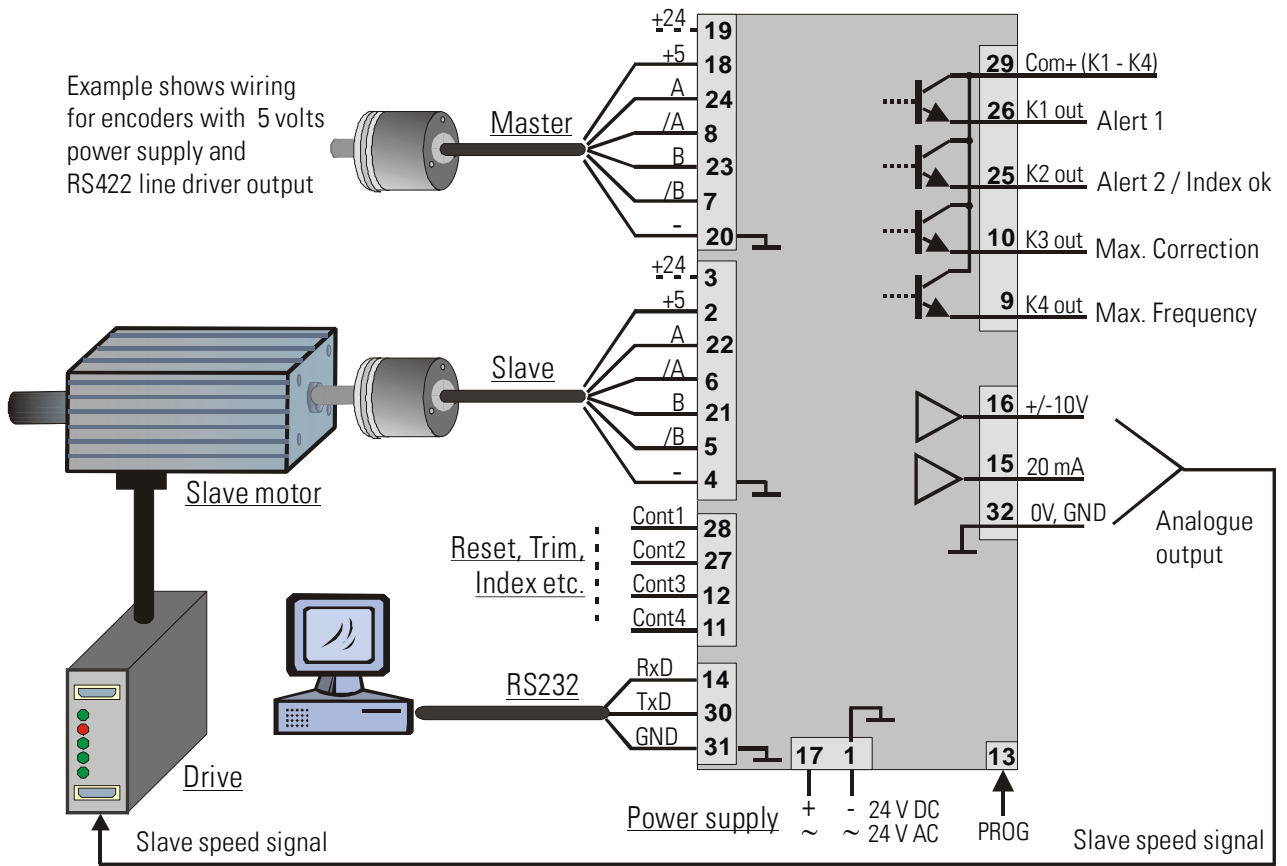
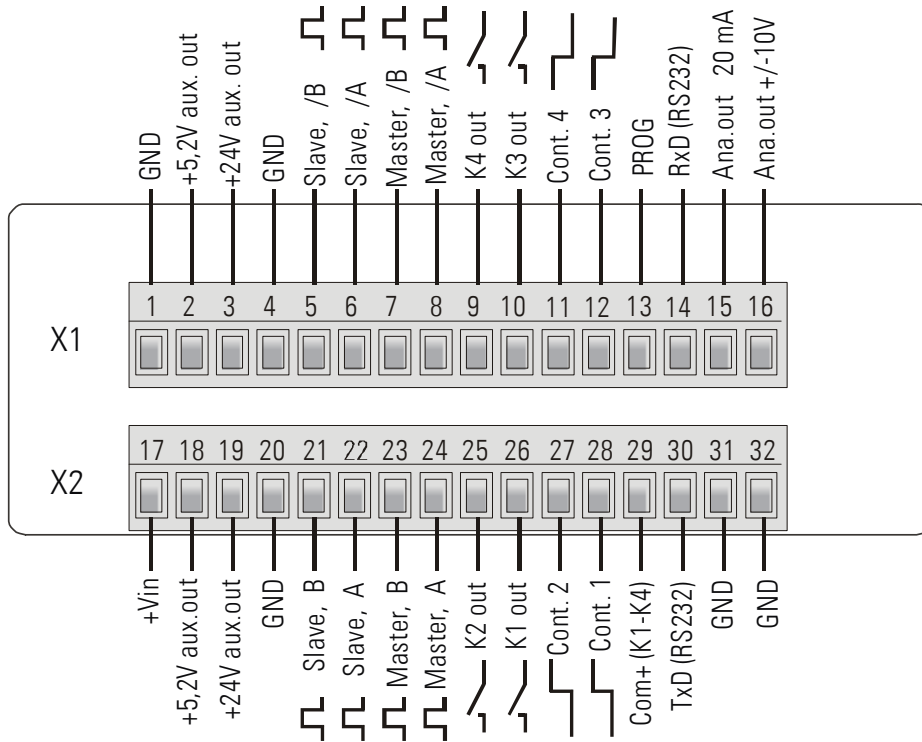

Terminal	Name	Function
01	GND	Common Ground Potential (0V)
02	+5,2V out	Aux. output 5.2V/150 mA for encoder supply
03	+24V out	Aux. output 24V/120 mA for encoder supply
04	GND	Common Ground Potential (0V)
05	Slave, /B	Slave encoder, channel /B (B inverted)
06	Slave, /A	Slave encoder, channel /A (A inverted)
07	Master, /B	Master encoder, channel /B (B inverted)
08	Master, /A	Master encoder, channel /A (A inverted)
09	K4 out	Digital output K4, transistor PNP 30 volts, 350 mA
10	K3 out	Digital output K3, transistor PNP 30 volts, 350 mA
11	Cont.4	Programmable control input
12	Cont.3	Programmable control input
13	(PROG)	(for download of new firmware only, not for general use)
14	RxD	Serial RS232 interface, input (Receive Data)
15	Ana.out 20 mA	Analogue output 0 – 20 mA (Slave speed reference) **)
16	Ana.out +/-10V	Analogue output -10V ... 0 ... +10V (Slave speed reference) **)
17	+Vin	Power supply input, +17 – 40 VDC or 24 VAC
18	+5,2V out	Aux. output 5,2V/150 mA for encoder supply
19	+24V out	Aux. output 24V/120 mA for encoder supply
20	GND	Common Ground Potential (0V)
21	Slave, B	Slave encoder, channel B (non-inverted)
22	Slave, A	Slave encoder, channel A (non-inverted)
23	Master, B	Master encoder, channel B (non-inverted)
24	Master, A	Master encoder, channel A (non-inverted)
25	K2 out	Digital output K2, transistor PNP 30 volts, 350 mA
26	K1 out	Digital output K1, transistor PNP 30 volts, 350 mA
27	Cont.2	Programmable control input
28	Cont.1	Programmable control input
29	Com+ (K1-K4)	Common positive input for transistor outputs K1-K4
30	TxD	Serial RS232 interface, output (Transmit Data)
31	GND	Common Ground Potential (0V)
32	GND	Common Ground Potential (0V) for DC or AC power supply

*) 120 mA and 150 mA are per encoder, i.e. total maximum currents are 240 mA and 300 mA

**) In general, the voltage output terminal 16 should be used for the slave speed signal

3.1. Power Supply

The BY340 synchronizer accepts both, a 17 – 40 volts DC power or a 24 volts AC power for supply via terminals 17 and 1. The current consumption depends on the level of the input voltage and some internal conditions; therefore it can vary in a range from 100 – 200 mA (auxiliary currents taken from the unit for encoder supply not included).

3.2. Auxiliary Outputs for Encoder Supply

Terminals 2 and 18 provide an auxiliary output with approx. +5.2 volts DC (300 mA totally).
Terminals 3 and 19 provide an auxiliary output with approx. +24 volts DC (240 mA totally)

3.3. Impulse Inputs for Incremental Encoders

All input characteristics of the impulse inputs can be set by the parameter menu, for each of the encoders separately. Depending on the application the unit can accept single channel information (input A only) or quadrature information (A / B, 90°). In theory, any of the following encoder characteristics would be applicable:

- Symmetric differential signals according to RS422 standard
- TTL inputs at a level of 3.0 to 5 volts (differential, with inverted signal)
- TTL inputs at a level of 3.0 to 5 volts (single-ended) *)
- HTL signals at a 10 – 30 volts level
(alternatively differential A, /A, B, /B, or single-ended A, B only)
- Impulses from photocells or proximity switches etc. providing a HTL level (10 – 30 volts)
- Proximity switches according to NAMUR (2-wire) standard
(may need additional remote resistor)

*) requires special settings of the threshold parameters, see "Special parameters F08"



- For trouble-free angular synchronization it is mandatory to use quadrature encoders with channels A and B or with channels A, /A, and B, /B (90° phase displacement).
- Where the impulse level is HTL (10 – 30 volts) you can use either single-ended signals (A and B only) or differential signals (A, /A, B, /B)
- Where the impulse level is TTL or RS422, it is strictly recommended to use symmetric differential signals (with inverted channels /A and /B).
Under industrial environment conditions, single-ended TTL signals may cause serious problems due to insufficient EMC immunity of the signal lines

3.4. Control Inputs Cont.1 – Cont.4

These inputs can be configured for remote functions like Reset, Phase trimming, Index evaluation or display selection purpose.

All control inputs require HTL level. They can be individually set to either NPN (switch to -) or PNP (switch to +) characteristics. For applications where edge-triggered action is needed, the menu allows to set the active edge (rising or falling). The Control inputs will also accept signals with Namur (2-wire) standard.



For reliable operation of the Control Inputs a minimum impulse duration of 50 μ sec. must be ensured. Especially when using the Z marker pulse of a HTL encoder for index tracking, please verify that this minimum duration can be kept even with maximum speed of the machine

3.5. Switching Outputs K1 – K4

BY340 provides four digital outputs to signal control states like “out of synchronization” or “Index o.k.”. K1 – K4 are fast-switching and short-circuit-proof transistor outputs with a switching capability of 5 – 30 volts / 350 mA each. The switching voltage of the outputs must be applied remotely to the Com+ input (terminal 29)

3.6. Serial Interface

The serial RS232 interface can be used for the following purposes:

- Set-up of the unit by PC with use of the OS32 PC software
- Remote change of parameters during operation
- Remote readout of actual values by PLC or PC

The figure below explains the connection between the BY340 unit and a PC using the standard Sub-D-9 serial connector

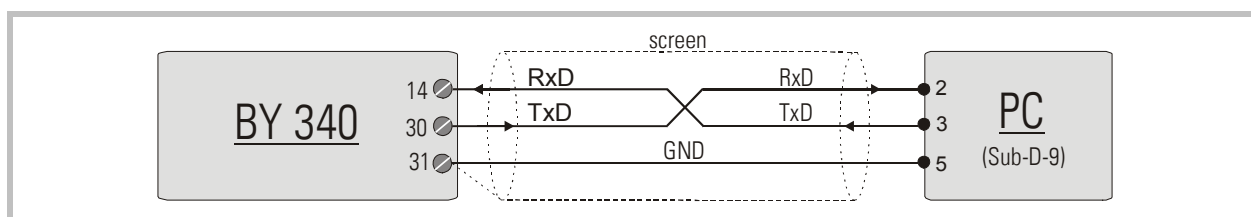

For details of the serial communication protocol, please refer to the special “Serpro” manual.

3.7. Analogue Outputs

The unit provides a voltage output of +/- 10 volts (load = 3 mA), and a current output of 0 – 20 mA (load = 0 – 270 Ohms), both at a resolution of 14 bits (13 bits + sign).

With most standard applications the voltage output is used as a speed reference signal, connected to the speed input of the Slave drive.

4. Principle of Operation

4.1. Synchronization

The Synchro controller receives full positional information about the master axis by means of the Master encoder. This incremental information can be scaled by means of the Master Scaling Factor (subsequently named Factor1). From this information the unit can calculate an analogue speed output signal which is necessary to make the Slave axis exactly follow to the Master.

The feedback of the actual position of the Slave axis is given by the Slave encoder. This information uses a separate impulse scaling by means of the Slave Scaling Factor (subsequently named Factor2).

Master position and Slave position are compared continuously, and the analogue output is updated correspondingly within very short cycle times of only about 100 µsec. As a result, both positions can be kept inside an error window of typically +/- 5 encoder increments (e.g. the Slave may lead or lag the Master by a few encoder increments, but will never loose position)

It is easy to understand, that this kind of positional and angular synchronization includes at the same time error-free speed synchronization of Master and Slave.

When we move the Master forward or reverse by a distance "d_{Master}", at the same time the Slave will move forward or reverse by a distance "d_{Slave}", under consideration of the impulse scaling factors Factor1 and Factor2. In general Factor1 is the parameter to change the speed ratio, and Factor2 is considered as a machine constant.

With most of the applications it is desirable to have proportional characteristics of Factor1, i.e. we like to increase the Slave speed when we increase Factor1.

Some application however may require reciprocal characteristics (e.g. when we use the unit for a rotary cutter application where Factor1 is used to set the cutting length. In this case, higher setting requires lower Slave speed, i.e. Factor1 has to operate reciprocally.

Both, proportional and reciprocal characteristics can be selected by parameter. Depending on these settings, the distances (and also the speeds) follow to one of the formulae below:

<u>Proportional Operation</u> :	$d_{\text{Slave}} = d_{\text{Master}} \times \frac{\text{Factor1}}{\text{Factor2}}$
<u>Reciprocal Operation</u> :	$d_{\text{Slave}} = d_{\text{Master}} \times \frac{1}{\text{Factor1}} \times \frac{1}{\text{Factor2}}$

4.2. Mechanical Phase and Position Considerations

Normally the synchronizer would always keep the angular phase or relative position between Master and Slave, which has existed while the unit has been powered up, or which has been defined manually while the unit was kept in the Reset state.

However it may be desirable to adjust the relative position in standstill or on the fly, by means of manual or remote commands, or even to set a certain position automatically, triggered by external events. For this reason, phase trimming functions and index functions have been designed, which can be assigned to either the front keys or the control inputs. Once the desired phase adjust commands have been assigned, the final function can be specified by setting of the appropriate Operating Mode of the unit (see 5.)

4.2.1. Phase Trimming under Timer Control (Modes 1 – 4 and 7 – 8)

Activating one of the +/-Trim commands allows to temporary run the Slave at a speed which is slightly higher (Trim+) or slightly lower (Trim-) than the correct synchronous speed, which results in a displacement of phase between Master and Slave (Slave leads or lags the Master). The differential speed to displace the phase is parameter adjustable. The system returns to closed-loop synchronous operation in a new relative position, as soon as the Trim command is released again.

4.2.2. Phase Trimming under Impulse Stepper Control (Modes 5 and 6)

With this mode of operation the +/-Trim commands must be assigned to two of the Control Inputs, which then operate as impulse inputs from a remote source (push button or PLC or else). Every impulse applied to the Trim+ input will advance the Slave by one differential increment*) and every impulse applied to the Trim- input will retard the Slave with respect to the Master. This method allows adjusting the relative position step by step

4.2.3. Lead or Lag by a programmable distance (Mode 3)

With this mode, every impulse detected on the Index Master or Index Slave input will jump the Slave forward or reverse by a fixed distance, as set to the Offset register. This method of phase displacement allows toggling the relative phase between two or more scheduled operating positions (e.g. 0°, 90°, 180° and back to 0°).

4.2.4. Position Definition by Index Inputs (Modes 2, 6 and 8)

Index signals may be used do define and to automatically adjust mechanical positions or events between the drives (for an example see the figure under section 2.). Index signals can be generated by proximity switches, photo cells or by use of the marker pulse of a HTL encoder. Where you intend to use marker pulses from TTL encoders, you have to translate the Z and /Z information to HTL level before applying it to the controller.

While modes 2 and 6 are designed for immediate and tough correction of index errors, mode 8 provides a soft way of making corrections. The Trim register is used to approach a new position by means of an adjustable differential speed.



*) Mechanically, one differential increment equals to one Slave encoder increment divided by Factor2



- Please observe the minimum duration of 50 μsec. for index pulses
- Every index pulse must clearly mark one explicit and repeatable event within one machine cycle

5. Operating Modes

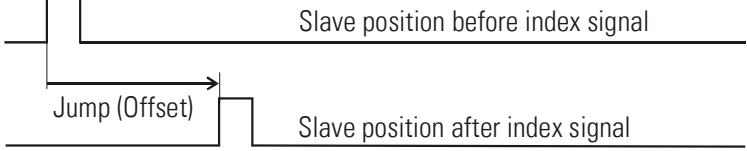

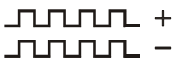

The operating mode (parameter F02.004) sets the functions of Trim and Index inputs, provided that these functions have been assigned to some Control Inputs or front keys.

Mode F02.004	Trim Input Function	Index Input Function	Impulse scaling (Slave : Master)
1	+/- Phase trim by internal timer. Temporary change of Slave speed while one of the Trim commands is on.	No Function	Fact 1 : Fact 2
2	Similar to Mode 1	Index control with adjustable phase 	Fact 1 : 1.00000
3	Similar to Mode 1	Index Master: Slave jumps forward Index Slave: Slave jumps reverse 	Fact 1 : Fact 2
4	Similar to Mode 1	<u>Motor Potentiometer Function:</u> Index Master: Increment Factor1 (+++) Index Slave: Decrement Factor1 (---)	Fact 1 : Fact 2
5	Phase trim by external pulse source 	No Function	Fact 1 : Fact 2
6	Phase trim by external pulse source 	Similar to Mode 2	Fact 1 : 1.00000
7	Similar to Mode 1	Similar to Mode 1	Fact 1 : Fact 2
8	Similar to Mode 1	Unlocked index operation with soft correction, for use with special applications like gantry cranes or precision register control.	Fact 1 : 1.00000

6. Keypad Operation

An overview of all parameters and explanations can be found under section 7.

The menu of the unit uses four keys, hereinafter named as follows:

			
PROG	UP	DOWN	ENTER

Key functions depend on the actual operating state of the unit. Essentially we have to describe three basic states:

- Normal operation
- General setup procedure
- Direct fast access to scaling factors

6.1. Normal Operation

In this mode the unit operates as a synchronous controller according to the settings defined upon setup. All front keys may have customer-defined functions according to the specifications met in the keypad definition menu F06 (e.g. Reset or Trim or else)









6.2. General Setup Procedure

The unit changes over from normal operation to setup level when keeping the  key down for at least 2 seconds. Thereafter you can select one of the parameter groups F01 to F09.

Inside the group you can now select the desired parameter and set the value according to need. After this you can either set more parameters or return to the normal operation.

The adjoining sequence of key operations explains how to change

Parameter number 052 of group F06 from the original value of 0 to a new value of 8

Step	State	Key action		Display	Comment
00	Normal operation			Actual Error	
01			> 2 sec.	F01	Display of the Parameter group
02	Level: Parameter group		5 x	F02 ... F06	Select group # F06
03				F06.050	Confirmation of F06. The first parameter of this group is F06.050
04	Level: Parameter numbers		2 x	F06.051 ... F06.052	Select parameter 052
05				0	Parameter 052 appears in display, actual setting is 0
06	Level: Parameter values		8 x	1 8	Setting has been modified from 0 to 8
07				F06.052	Save the new setting (8)
08	Level: Parameter numbers			F06	Return to level parameter groups
09	Level: Parameter groups			Actual Error	Return to normal operation
10	Normal operation				



During the general setup procedure all control activities remain disabled. New parameter settings become active after return to normal operation only.

6.3. Direct Fast Access to Speed Ratio Setting

To get to the fast access routine, please press both



and



at the same time





This will access the parameter group F01 right away. To change the settings follow the same procedure as already described above. Besides the advantage of direct access, the fundamental difference to general setup is the following:



During the fast access procedure all control functions remain fully active. Access is limited to Factor settings; no other parameters can be changed.

6.4. Change of Parameter Values on the Numeric Level











The numeric range of the parameters is up to 6 digits. Some of the parameters may also include a sign. For fast and easy setting of these values the menu uses an algorithm as shown subsequently. During this operation the front keys have the following functions:

			
PROG	UP	DOWN	ENTER
Saves the actual value shown in the display and returns to the parameter selection level	Increments the highlighted (blinking) digit	Decrements the highlighted (blinking) digit	Shifts the cursor (blinking digit) one position to the left, or from utmost left to right

With signed parameters the left digit scrolls from **0 to 9** and then shows “-„ (negative) and “-1” (minus one). The example below shows how to change a parameter from the actual setting of 1024 to the new setting of 250 000.

This example assumes that you have already selected the parameter group and the parameter number, and that you actually read the parameter value in the display.

Highlighted digits appear on colored background.

Step	Display	Key action	Comment
00	001024		Display of actual parameter setting, last digit is highlighted
01		 4 x	Scroll last digit down to 0
02	001020		Shift cursor to left
03	001020	 2 x	Scroll highlighted digit down to 0
04	001000	 2 x	Shift cursor 2 positions left
05	001000		Scroll highlighted digit down to 0
06	000000		Shift cursor left
07	000000	 5 x	Scroll highlighted digit up to 5
08	050000		Shift cursor left
09	050000	 2 x	Scroll highlighted digit up to 2
10	250000		Save new setting and return to the parameter number level

6.5. Code Protection against Unauthorized Keypad Access

Parameter group F09 allows to define an own locking code for each of the parameter menus. This permits to limit access to certain parameter groups to specific persons only.

When accessing a protected parameter group, the display will first show "CODE" and wait for your entry. To continue keypad operations you must now enter the code which you have stored before, otherwise the unit will return to normal operation again.

After entering your code, press the ENTER key and keep it down until the unit responds. When your code was correct, the response will be "YES" and the menu will work normally. With incorrect code the response will be "NO" and the menu remains locked.

6.6. Return from the Programming Levels and Time-Out Function



At any time the PROG key sets the menu one level up and finally returns to normal operation. The same step occurs automatically via the time-out function, when during a period of 10 seconds no key has been touched.

Termination of the menu by automatic time-out will not store new settings, unless they have already been stored by the PROG key after editing.

6.7. Reset all Parameters to Factory Default Values

Upon special need it may be desirable to set all parameters back to their original factory settings (e.g. because you have forgotten your access code, or by too many change of settings you have achieved a complex parameter state). Default values are indicated in the parameter tables shown later.

To reset the unit to default, please take the following steps:

- Switch power off
- Press  and  simultaneously
- Switch power on while you keep down both keys



Where you decide to take this action, please note that all parameters and settings will be lost, and that you will need to run a new setup procedure again.

7. Menu Structure and Description of Parameters

All parameters are arranged in a reasonable order of functional groups (F01 to F09)
 You must only set those parameters which are really relevant for your specific application.
 Unused parameters can remain as they actually are.

7.1. Summary of the Menu

This section shows a summary of the parameter groups, with an assignment to the functional parts of the unit.

Group	Function	Group	Function
F01	Impulse Scaling	F03	Definitions for the Master Encoder
000	Factor 1 (Master)	026	Encoder Properties
001	Factor 2 (Slave)	027	Edge Counting
002	Reserved	028	Counting Direction
003	Reserved	029	Multiplier
F02	Operational Setting	030	Reserved
004	Operating Mode	031	Reserved
005	Trim Time	F04	Definitions for the Slave Encoder
006	Integration Time	032	Encoder Properties
007	Correction Divider	033	Edge Counting
008	Factor 1 Scaling	034	Counting Direction
009	Factor 1 Minimum	035	Reserved
01	Factor 1 Maximum	036	Reserved
011	Sampling Time	037	Reserved
012	Wait Time	F05	Analogue Output Settings
013	Max. Master Frequency	038	Analogue Format
014	Ramp Time	039	Offset Correction
015	Stop-Ramp Time	040	Gain Correction
016	Alert 1	041	Max. Correction
017	Alert 2	042	Offset Total
018	Phase Offset*	043	Gain Total
019	Slave Pulses Index*	044	Reserved
020	Phase Adjust*	045	Reserved
021	Master Index Divider		
022	Index Window		
023	Max. Index Correction		
024	Reserved		
025	Reserved		

*) Parameters for Index Modes are only available with Software version BY34002 and higher

F06	Command Assignment
046	Key Up Function
047	Key Down Function
048	Key Enter Function
049	Input 1 Configuration
050	Input 1 Function
051	Input 2 Configuration
052	Input 2 Function
053	Input 3 Configuration
054	Input 3 Function
055	Input 4 Configuration
056	Input 4 Function
057	Reserved
F07	Serial communication
058	Unit Number
059	Serial Baud Rate
060	Serial Format
061	Reserved
062	Reserved
063	Reserved
F08	Special functions
064	Input Filter
065	Trigger Threshold 1
066	Trigger Threshold 2
067	Brightness
068	Frequency Control
069	Factor Store Configuration
070	Display Time
071	Reserved

F09	Keypad protection codes
072	Protect Group F01
073	Protect Group F02
074	Protect Group F03
075	Protect Group F04
076	Protect Group F05
077	Protect Group F06
078	Protect Group F07
079	Protect Group F08
080	Protect Group F09
081	Reserved
082	Reserved
083	Reserved
084	Reserved
085	Reserved
086	Reserved
087	Reserved

The following schematics shows how in principle the parameter blocks are assigned to the various elements and functions of the controller.

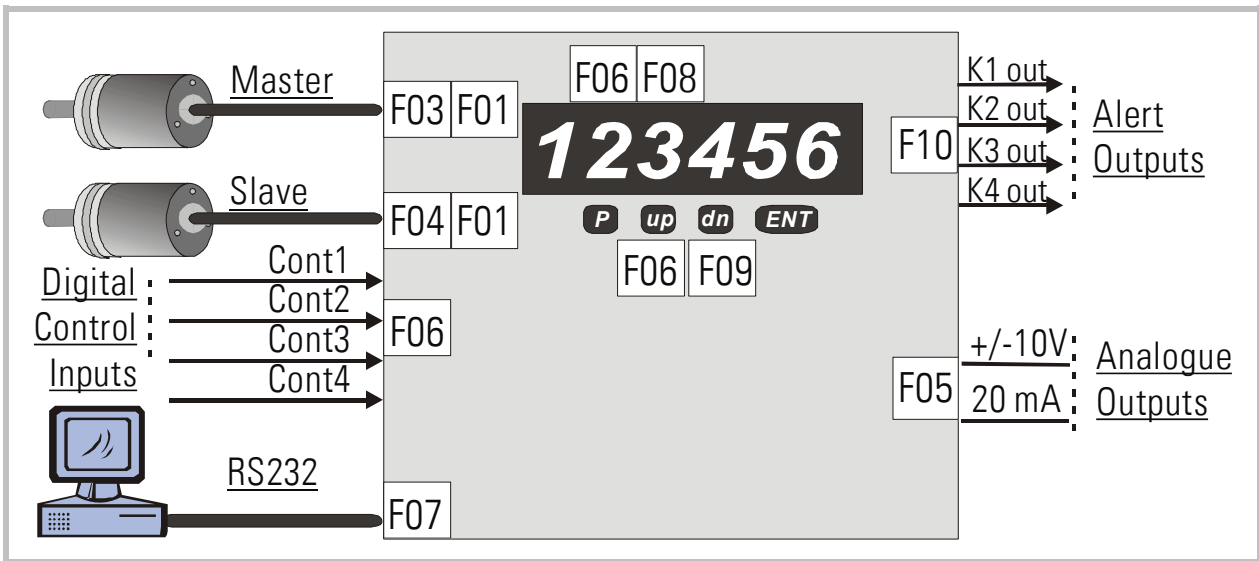

7.2. Description of the Parameters

7.2.1. Impulse Scaling

F01		Range	Default
F01.000	Factor 1: Impulse scaling factor for Master encoder.	0.00001 ... 9.99999	1.00000
F01.001	Factor 2: Impulse scaling factor for Slave encoder.	0.00001 ... 9.99999	1.00000

7.2.2. Operational Settings

F02		Range	Default
F02.004	Operation mode (see table under section 5.)	1 ... 8	1
F02.005	Trim Time: Rate of change, to be entered as a number of cycles (1 cycle = 250 µsec), for phase trimming, when the +/- Trim command are activated	0 ... 9999 0000 = Trim off 0001 = fast change 9999 = slow change	10
F02.006	Integration Time: Time constant for the phase integrator, which avoids positional errors, also to be entered as a number of cycles (1 cycle = 250 µsec)	0 ... 9999 0000 = Integrator off 0001 = fast speed 9999 = slow speed	500

F02		Range	Default
F02.007	<p>Correction Divider: Function to provide a digital attenuation of the phase correction signal that is produced, when the drive on mechanical grounds (dead band or backlash) cannot respond. In such a case, it is not desirable to make corrections immediately. The "Correction Divider" provides a window for the drive "backlash", within which the controller produces no correction and a division of the differential error count. 0 = No window, Reaction to 1 increment, no division 1 = Window +/- 1 increments, error division by 2 2 = Window +/- 2 increments, error division by 4 3 = Window +/- 4 increments, error division by 8 etc.</p>	0 ... 9	0
F02.008	<p>Factor 1 Scaling: This factor allows scaling of the remote Factor 1 entry to "user units" or to adapt the numeric value of Factor 1 to the application.</p> <p> It is essential, for all steps of set-up, to program F1-Scaling Factor to 1.00000 first in order to avoid confusions with factor calculations. This ensures that the Factor setting corresponds to the real operative Factor 1. Once the set-up procedure is terminated, set F1-Scaling Factor to the numeric value that later should correspond to an operative value of 1.0000 for Factor 1. <u>Example:</u> If the operator desires to set 3.50000 instead of 1.00000, set F1-Scaling Factor to 3.50000. For all factor calculations, please be aware if you operate with a proportional or a reciprocal characteristic of Factor1!</p>	0.00001 ... 9.99999	1.00000
F02.009 F02.010	<p>Factor 1 Minimum: Factor 1 Maximum: These are limitations of the setting range of Factor 1 and out of range settings will be overwritten by the appropriate min or max value. With Factor 1 Minimum set to 0.95000 and Factor 1 Maximum set to 1.05000, the operator is limited to a +/- 5% variation of the speed ratio.</p>	0.00001 ... 9.99999	0.00001 9.99999

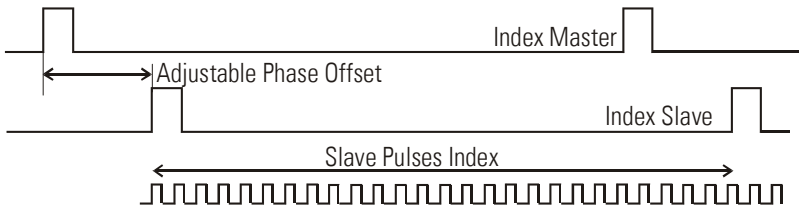
F02		Range	Default
F02.018	<p>Phase Offset *</p> <p>Allows setting a position offset between the Master index and the Slave Index. When set to zero, the controller will align the active edges of both index signals. Setting is in Slave encoder increments.</p> 	-199999 - 199999	0
F02.019	<p>Slave Pulses Index *</p> <p>Number of Slave encoder pulses between two slave index signals</p>	1 – 999999	5000
F02.020	<p>Phase Adjust *</p> <p>With index operation only (Mode 2 and 6):</p> <p>Digital attenuation of the response upon marker pulse errors.</p> <ol style="list-style-type: none"> 1: full correction with each index check, i.e. 100% 2: correction by several steps with 50% of the residual error 3: correction by several steps with 33% of the residual error 4: correction by several steps with 25% of the residual error 5: correction by several steps with 20% of the residual error etc. <p>The setting depends on the dynamics of the drive and the maximum speed. <u>Example:</u> If a marker pulse arrives every 20 msec. but the drive cannot correct the largest error in 20msec, it will lead to instability if the next correction is executed before the previous is completed. In such a case the phase correction percentage must be reduced.</p>	1 - 9	1
F02.021	<p>Master Index Divider *</p> <p>This is a programmable index divider for the master marker pulses. It permits different numbers of marker pulses from the master and the slave.</p> <p>For the same reason as clarified above, we also recommend to use the divider with very short sequences of marker pulses, to allow the drive to stabilize before the next index correction starts.</p>	1 - 99	1

*) Parameters for Index Modes are only available with Software version BY34002 and higher

F02		Range	Default
F02.022	Index Window * Sets a window (encoder increments) where the slave index pulse should be within with regard to the actual master index position. The output is ON when the Slave index is inside the tolerance window	1 - 9999	10
F02.023	Max. Index Correction * The response to registered marker pulse errors is limited to the value set here (encoder increments). Works similar to parameter "Phase Adjust" but allows absolute limitation of the amount of index correction to a level that can be handled by the drive.	1 - 32000	32000

*) Parameters for Index Modes are only available with Software version BY34002 and higher



Important Hints for Index Operation only:

- When using the +/-Trim function with one of the index modes, the Trim impulses will automatically take along the Phase Offset setting, i.e. the Trim function can also be used to manually adjust the desired Phase Offset.
- Phase Offset settings adjusted with use of the +/-Trim function will be active until to next power-down only, unless you apply a "Store EEPROM" command before switching power off
- With operating modes 2 and 6 it is most important to set the correct number of encoder pulses between two Slave index pulses to parameter F02.019. Bad settings may cause severe instability!
- With mode 8, when the accurate encoder impulse number between two Slave index pulses is unknown or can vary, it is also acceptable to set parameter F02.019 to an estimated number of impulses. However, the setting must be lower or equal but not higher than the real number of encoder pulses between two index pulses. Index errors higher than half of the F02.019 register setting will not be corrected with mode 8
- As soon as one of the index modes is used, output K2 will operate as "Index ok" output and the setting of Alert 2 is inactive

7.2.3. Definitions for the Master Encoder

F03		Range	Default
F03.026	Encoder properties	0 ... 3	1
	0= Differential Impulses A, /A, B, /B (2 x 90°) incl. inv.		
	1= Single-ended Impulses A, B (2 x 90°) without inv.		
	2= Differential Impulses A, /A for count Differential Signal B, /B can indicate static direction		
	3= Single-ended Impulses A for count Single-ended Signal B can indicate static direction		
F03.027	Edge counting	0 ... 2	0
	0= Simple edge evaluation (x1)		
	1= Double edge evaluation (x2)		
	2= Full quadrature edge evaluation (x4)		
F03.028	Counting direction	0 ... 1	0
	0= Up when A leads B		
	1= Down when A leads B		
F03.029	n.a.	n.a.	

7.2.4. Definitions for the Slave Encoder

F04		Range	Default
F04.032	Encoder properties	0 ... 3	1
	0= Impulses A, /A, B, /B (2 x 90°) incl. inv.		
	1= Impulses A, B (2 x 90°) without inv.		
	2= Impulses A, /A for count Signals B, /B can indicate static direction		
	3= Impulses A for count Signals B can indicate static direction		
F04.033	Edge counting	0 ... 2	0
	0= Simple (x1)		
	1= Double (x2)		
	2= Full quadrature (x4)		
F04.034	Counting direction	0 ... 1	0
	0= Up when A leads B		
	1= Down when A leads B		
F04.035	n.a.		

n.a. = not applicable

7.2.5. Analogue output definitions

F05		Range	Default
F05.038	Control characteristics and analogue format	0 ... 3	0
	0= The slave speed changes proportionally to the Factor 1 setting, i.e. doubles motor speed when changing Factor 1 from 1.00000 to 2.00000. (suitable for most of all applications) Output scaled for a -10 volts ... +10 volts signal		
	1= The slave speed is reciprocal to the Factor 1 setting, i.e. halves the motor speed when changing Factor 1 from 1.00000 to 2.00000. (suitable for rotating cutter applications when Factor 1 represents the length preset) Output scaled for a -10 volts ... +10 volts signal		
	2= Similar to setting 0, but Output scaled for a -20 mA ... +20 mA signal		
	3= Similar to setting 1, but Output scaled for a -20 mA ... +20 mA signal		
F05.039	Offset Correction: Digital setting of analogue offset on correction signal.	-10.000 ... +10.000 (volts)	0.000
F05.040	Gain Correction: Digital setting of the proportional gain of the control loop. Setting to 2.048 results in a response of 1 mV per error bit. Recommended setting: 0.500...5.000 (Gain Correction / 2048 = x.xxx volts per error bit).	0 ... 51.200	2.000
F05.041	Max. Correction: Limitation of the output voltage of the correction signal (correction will not exceed this setting)	0 ... 10.000 (volts)	2.000
F05.042	Offset Total: Digital setting of analogue offset of the overall analogue output signal.	-10.000 ... +10.000 (volts)	0.000
F05.043	Gain Total: Sets the full-scale output voltage at maximum master frequency, i.e. 9,000 means 9 volts at max. frequency	0 ... 11.000 (volts)	10.000

n.a. = not applicable

7.2.7. Characteristics and functions of the Control Inputs

F06		Range	Default	
F06.049	Switching characteristics of input „Cont.1“		0 ... 7	0
	0=	NPN (switch to -), function active LOW		
	1=	NPN (switch to -), function active HIGH		
	2=	NPN (switch to -), rising edge		
	3=	NPN (switch to -), falling edge		
	4=	PNP (switch to +), function active LOW		
	5=	PNP (switch to +), function active HIGH		
	7=	PNP (switch to +), falling edge		
F06.050	Function assignment to input „Cont.1“		0 ... 16	6
	0=	No function		
	1=	Reset		
	2=	Trim -		
	3=	Trim +		
	4=	n.a.		
	5=	n.a.		
	6=	Integrator off		
	7=	Store EEPROM		
	8=	Scroll Display		
	9=	Parameter Disable		
	10=	Clear Min. & Max.		
	11=	Index Slave		
	12=	Index Master		
	13=	n.a.		
	14=	Read front thumbwheels (model 641 only)		
15=	Stop Slave			
16=	n.a.			
F06.051	Switching characteristics of input „Cont.2“		See „Cont.1“ (F06.049)	
F06.052	Function assignment to input „Cont.2“		See „Cont.1“ (F06.050)	
F06.053	Switching characteristics of input „Cont.3“		See „Cont.1“ (F06.049)	
F06.054	Function assignment to input „Cont.3“		See „Cont.1“ (F06.050)	
F06.055	Switching characteristics of input „Cont.4“		0 – 3	 <p>no edge-triggered functions are possible with Cont.4</p>
	0=	NPN (switch to -) function active LOW		
	1=	NPN (switch to -) function active HIGH		
	2=	PNP (switch to +), function active LOW		
	3=	PNP (switch to +), function active HIGH		
F06.056	Function assignment to input „Cont.4“		See „Cont.1“ (F06.050)	

n.a. = not applicable



- Unconnected NPN inputs are always HIGH (internal pull-up resistor)
Unconnected PNP inputs are always LOW (internal pull-down resistor)
- When you use Index operation, it is mandatory to use Control Input 1 as Master Index (F06.050 = 12) and Control Input 2 as Slave Index (F06.052 = 11).
These two inputs are no more available for other purpose.
- Index inputs must always be edge-triggered, i.e. parameters F06.049 and F06.051 must be either 2 or 3 or 6 or 7 when you use index operation.
- Where you like visualize Index Signals on your PC screen by means of the OS32 Operator Software, you must temporary set the inputs to static operation. The corresponding light boxes on the screen are not suitable to display dynamic signals. Please return to edge- triggered operation after the test.

7.2.8. Serial communication parameters

F07		Range	Default
F07.058	Serial device address (unit number)	11 ... 99	11
F07.059	Serial baud rate	0 ... 6	0
	0= 9600 Baud		
	1= 4800 Baud		
	2= 2400 Baud		
	3= 1200 Baud		
	4= 600 Baud		
	5= 19200 Baud		
	6= 38400 Baud		
F07.060	Serial data format	0 ... 9	0
	0= 7 Data, Parity even, 1 Stop		
	1= 7 Data, Parity even, 2 Stop		
	2= 7 Data, Parity odd, 1 Stop		
	3= 7 Data, Parity odd, 2 Stop		
	4= 7 Data, no Parity, 1 Stop		
	5= 7 Data, no Parity, 2 Stop		
	6= 8 Data, Parity even, 1 Stop		
	7= 8 Data, Parity odd, 1 Stop		
	8= 8 Data, no Parity, 1 Stop		
	9= 8 Data, no Parity, 2 Stop		

7.2.9. Special functions

F08		Range	Default
F08.064	Digital input filter: <u>must be set to "0"</u> .	0 ... 3	0
F08.065	Trigger threshold for encoder1 inputs *)	30 ... 250	166
F08.066	Trigger threshold for encoder2 inputs *)	30 ... 250	166
F08.067	Brightness of the 7-segment LED display	0 ... 4	0
	0= 100% of maximum brightness		
	1= 80% of maximum brightness		
	2= 60% of maximum brightness		
	3= 40% of maximum brightness		
	4= 20% of maximum brightness		
F08.068	Frequency Control: <u>must be set to "0"</u>	0 ... 1	0
F08.069	Factor Storage	0 ... 1	0
	0= Factor temporary active until next power-down **)		
	1= Factor stored to EEPROM for enduring use **)		
F08.070	Display Time: Update time (sec.) for display only	0.005 ... 9.999	0.050

*) Must be set to the default value (166) for any kind of input signals, except for single-ended TTL signals which require a setting of 35.

**) Refers only to those changes of the speed ratio settings where the "Direct Fast Access" menu has been used (see 6.3)

7.2.10. Keypad protection codes

F09		Range	Default
F09.071	Protected group F01	0 = no protection 1 – 999 999 = Protection code for the actual parameter group	0
F09.072	Protected group F02		
F09.073	Protected group F03		
F09.074	Protected group F04		
F09.075	Protected group F05		
F09.076	Protected group F06		
F09.077	Protected group F07		
F09.078	Protected group F08		
F09.079	Protected group F09		

8. Description of Commands and Outputs

8.1. Commands

No.	Command	Description	Assignment to	
			Keypad	Input
0	Do nothing		yes	yes
1	Reset	Sets the internal differential counter and the analogue correction signal to zero. Both drives run solely in analogue synchronization (open loop) whilst activated	yes	yes
2 3	Trim- Trim+	Provides a temporary lower or higher slave speed which results in a phase displacement between the motor shafts. When releasing the trim command, the drives will synchronize again in their new relative position. In Modes 5 and 6 impulses are required to change the position step by step	yes	yes
4	n.a.			
5	n.a.			
6	Integrator off	This command sets the phase integrator to 0. This prevents the integrator from building up error when the drives are stopped, but not in a perfect synchronous position. This prevents any leap in speed on restart	yes	yes
7	Store EEPROM	Stores actual operational settings to the EEPROM, so they remain available also after power down.	yes	yes
8	Scroll Display	Selects the source of the digital display. The front LEDs indicate what the actual reading is	yes	yes
	No.	LED Display	L1 (red)	L2 (yellow)
	1	Position error (differential counter)	OFF	OFF
	2	Position error (bar graph display, see diagram)	OFF	OFF
	3	Actual Master frequency (Hz)	ON	OFF
	4	Recorded Minimum Error since last "Clear min-max" command	OFF	ON
	5	Recorded Maximum Error since last "Clear min-max" command	ON	ON
	6	Impulse count between two Master index pulses	blink	OFF
	7	Impulse count between two Slave index pulses	OFF	blink
	8	Display OFF (only two decimal points are lit to indicate operation state)	OFF	OFF

n.a. = not applicable



Bar graph display with reference to the actual synchronization error

The diagram shows positive errors only (Slave lags Master). Negative errors are mirror-inverted.

No.	Command	Description	Assignment to	
			Keypad	Input
9	Parameter Disable	Disables the keypad for any parameter access. Only commands assigned to the keypads will be accessible	no	yes
10	Clear Min. & Max	Sets the internal minimum and maximum error registers to the actual differential error.	yes	yes
11	Index Slave	Assigns the index pick-up function to the input (respectively Factor1 inc./dec. with Mode 4)	yes	yes
12	Index Master			
13	n.a.			
14	Read Thumbwheels	Reads and activates the Factor 1 setting from the front thumbwheel switches (model BY641 only)	yes	yes
15	Stop Slave	Ramps the Slave drive down to standstill using the "Stop Ramp". When released, the Slave ramps up again and locks into synchronization	yes	yes
16	n.a.			

n.a. = not applicable

8.2. Outputs

No.	Output	Terminal
K1	Alert 1	X2 / 26
K2	Alert 2 / Index ok The alert outputs indicate that the preset tolerance band has been exceeded in one direction or the other, as specified by the parameters "Alert 1" and "Alert 2". With all index modes, K2 operates as "Index ok" output	X2 / 25
K3	Max. Correction Indicates that the limitation of the correction voltage has been activated to keep the correction inside "Max. Correction"	X1 / 10
K4	Max. Frequency Indicates that the actual master frequency is higher than the limit set by parameter "Max. Frequency"	X1 / 9

9. Steps for Commissioning

For easy and uncomplicated commissioning of the BY340 / 641 controllers you need a PC with the operator software OS32. Connect your PC to the synchronizer as shown in section 3.6 and start the OS32 software. The following screen will appear:

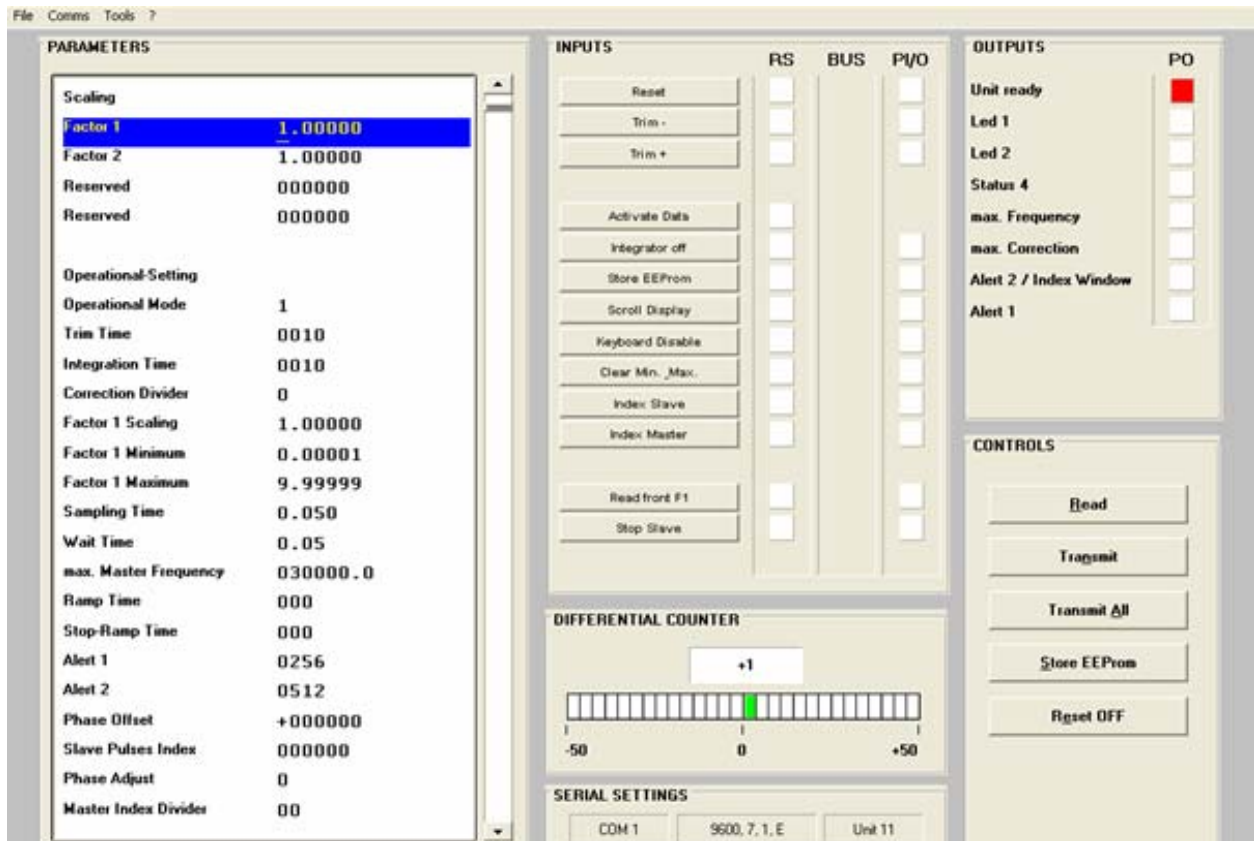

Where instead you find the mask blank with the indication „OFFLINE“ in the top bar, please click to the „Comms“ menu and check the serial settings of your PC.

Set all parameters in the Edit filed according to your needs, following the hints given in this manual. The following parameters should initially be set to the values as shown:

Number	Register	Initial Setting
F02.004	Operation mode	1
F02.006	Integration Time	0000
F02.007	Correction Divider	0
F05.040	Correction Gain	1.000
F05.041	Max. Correction	10.000

After entry of all parameters click to “Transmit All” followed by “Store EEPROM” to store all parameters to the BY340 or BY641 controller.



At this time, both drives (Master and Slave) must be adjusted to proper and stable operation over the full speed range. Slave drive settings must provide a maximum of dynamics and response (set ramps to zero, switch of any integral or differential component of the internal speed control loop, operate the drive with proportional speed control only, with the proportional Gain set as high as possible).

9.1. Running the Adjust menu

For adjustments of directions and control gains of the slave drive, you need to open the „Adjust“ menu available under „Tools“ in the main menu of the screen. To start the Adjust menu the first time, the Slave drive should be disabled for reasons of safety.

The screenshot shows the 'Adjust Menu' window with the following data:

Name	Value
Frequency ...	+5177
Counter Ma...	+627797
Counter Slave	+626163

The 'GAIN SETTINGS' section shows:

- Gain Correction: 1000
- Gain Total: 9926

The 'DIFFERENTIAL COUNTER' section shows a scale from -50 to +50 with a green bar at 0.

9.2. Set Directions of Rotation

The direction of rotation must be defined for both, master and slave encoder. Make sure the Reset is switched on when you do this (the softkey must show "Reset is ON")

- Move the Master encoder into **forward** direction (manually or by means of a remote speed signal to the Master drive). Observe the "Counter Master" value shown in the monitor window on the right. It must count up to positive values. Where you find it counts down or to negative, please click to button "Master Direction" to change the counting direction.
- Move the Slave encoder into forward direction (manually or by enabling the Slave drive while the Master is moving forward). Observe the "Counter Slave" value. It must again count up to positive values. Where you find it counts down or to negative, please click to button "Slave Direction" to change the counting direction.

9.3. Tuning the Analogue Output

- Switch Reset to ON by clicking to the corresponding softkey on the screen.
- Enable both, Master and Slave drive. Turn the speed signal for the Master to approximate 25% of the maximum speed. The Slave should now move, too. As a next step, switch the Reset to OFF by clicking to the Reset button (showing actually "Reset On"). This will activate the closed loop control.
- Observe the color bar and the value of the differential counter. There are the following two possibilities:
 - a. The bar graph moves to the right and the differential counter shows positive values. This indicates that the analogue output is too low. Please increase the setting of "Gain Total" by scrolling up with the arrow key on the right, or by shifting the slider into a more right position.
 - b. The bar graph moves to the left and the differential counter shows negative values. This indicates that the analogue output is too high. Please decrease the setting of "Gain Total" by scrolling down with the arrow key on the left, or by shifting the slider into a more left position.

"Gain Total" is set correctly when the bar graph remains in its centre position and the differential counter swings around zero (e.g. +/-8 counts)

- Turn speed signal for the master to approximately 80% of maximum speed. Continue to observe the color bar and the value of the differential counter and adjust "Gain Total" again if necessary.



You can reset the differential counter to zero at any time between, by cycling the "Reset" command.

9.4. Setting of the Proportional Gain

The register "Gain Correction" determines how strong the controller responds to position and speed errors of the drive. In principle, this setting therefore should be as high as possible. However, depending on dynamics and inertia of the whole system, too high gain values will produce stability problems.

Please try to increase the setting of Correction Gain from 0.500 to 1.000, 1500, 2.000, 2.500, 3.000 etc. However, as soon as you find unsteady operation, noise or oscillation, you must reduce the setting again correspondingly.

We also recommend to ramp up and down the master while checking the color bar and the differential counter for stable operation.

**Once you have successfully concluded these steps, you can exit the Adjust menu.
Your synchronous application is ready to work now.**

9.5. Hints for final operation

9.5.1. Using and Adjusting the Integrator

When, for stability reasons, you needed to keep your "Correction Gain" value low, any important non linearity in your drive system could cause changing phase errors with different speeds or loads (e.g. color bar deviates to right at low speed, stays in centre at medium speed and deviates to left at maximum speed).

Please note that a deviation of the color bar does not indicate a speed error at all, unless the differential counter shows figures outside a +/- 1024 error increment range. Inside this range, the speed is always error-free and deviations only refer to a constant number of encoder increments that the Master leads or lags the Slave.

Where your differential counter remains in an acceptable range around zero (e.g. -8....0....+8), there is no need to use the integrator and you should leave "Integration Time" set to 0000.

Where you feel that, despite of maximum settings of the proportional gains, your phase accuracy must still become better, set "Integration Time" to 50....40....30 20....10 or even lower. The Integrator will move the phase error always into a +/-6 increments error window. The lower the Integration Time setting, the faster it will catch up with the correct phase. Too low settings (= too high integration speeds) will however result in oscillation problems.



Too high settings of Gain-Correction and too low settings of the Integration Time will cause stability problems like oscillation or hunting of the Slave

9.5.2. Adjusting the Correction Divider

Where you find your color bar oscillates quickly around zero over several fields, this indicates your encoder resolution is too high with respect to mechanical clearance, backlash of tooth belts or other tolerances. To eliminate this, set Correction Divider to 1 or 2 or higher until you observe more stable operation.

10. Appendix for model BY 641

10.1. Relay Outputs

While model BY340 provides high-speed transistor outputs only, model BY641 provides four additional relay outputs, operating in parallel to the high-speed transistor outputs K1 – K4.

All electrical connections of BY 641 are fully similar to BY 340, except that with BY 641 models the back plane is equipped with four additional terminal strips (3 positions each).

Terminal X3 represents output K1 and terminal X6 represents output K4.

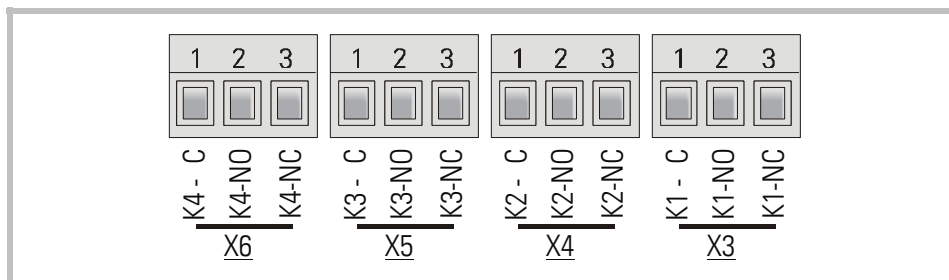

10.2. Front Thumbwheel Switches

Moreover, the BY 641 models provide thumbwheel switches on the front panel, for simple and easy setting of the speed ratio by means of Factor1. This is how the front switches work:

- Upon power-up the unit will read the thumbwheel settings and overwrite the internal Factor 1 setting correspondingly, i.e. the synchronization will use the front thumbwheels.
- When during operation you change the thumbwheel setting, this will not affect the synchronization until you apply a “Read Thumbwheel” command to the unit. You can assign this command to either one of the front keys or to one of the Control Inputs, as shown under sections 7.2.6 and 7.2.7
- When the front thumbwheels are all set to zero, the controller will automatically use the internal Factor 1 as entered by menu.

11. Specifications and Dimensions

AC power supply	:	24 V~ +/-10%, 15 VA
DC power supply	:	24V- (17 – 40V), approx. 100 mA (+ encoders)
Aux. encoder supply outputs:		2 x 5,2 VDC, 150 mA each 2 x 24V DC, 120 mA each
Inputs	:	2 universal encoder inputs 4 digital control inputs HTL ($R_i = 3.3 \text{ k}\Omega$) Low < 2.5 V, High > 10 V, min. pulse width 50 μ sec.
Counting frequency (per encoder)	:	RS422 and TTL differential: 300 kHz HTL single ended: 200 kHz TTL single-ended: 200 kHz
Switching outputs (all models)	:	4 fast power transistors 5 - 30V, 350 mA (b) Response time < 1 msec. (a),
Relay outputs (models BY641 only)	:	4 relays (dry changeover contacts) (b) AC switching capability max. 250 V/ 1 A/ 250 VA DC switching capability max. 100 V/ 1A/ 100 W
Serial link	:	RS232, 2400 – 38400 Bauds
Analogue outputs	:	0...+/- 10V (load max. 2 mA) 0...20mA (load max.270 Ohm) Resolution 14 bits, Accuracy 0.1% Overall response time < 1 msec. (a)
Ambient temperature	:	Operation: 0 - 45°C (32 – 113°F) Storage: -25 - +70°C (-13 – 158°F)
Housing	:	Norly UL94 – V-0
Display	:	6 Digit, LED, high- efficiency red, 15mm
Protection class (front side only)	:	BY 340: IP65 BY 641: IP20 (with use of the plexi-glass cover part # 64026 also IP65)
Protection class rear side	:	IP20
Screw terminals	:	Cross section max. 1.5 mm ² ,
Conformity and standards:		EMC 89/336/EEC: EN 61000-6-2 EN 61000-6-3 LV73/23/EEC: EN 61010-1

(a) Continuous serial communication may temporary increase response times

(b) Diode or RC filtering is mandatory when switching inductive loads

Dimensions of model BY340:

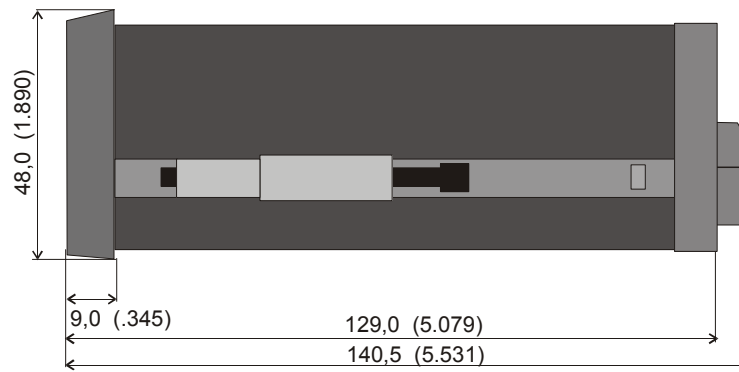
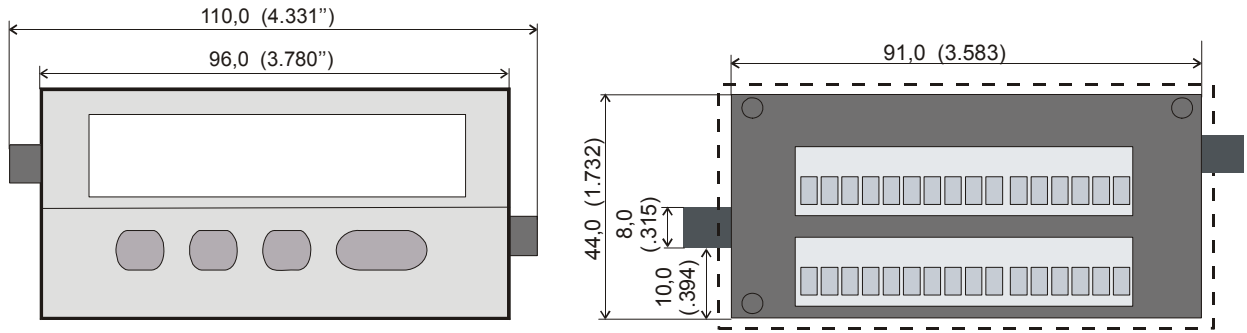

Panel cut out: 91 x 44 mm (3.583 x 1.732")

Dimensions of model BY641:

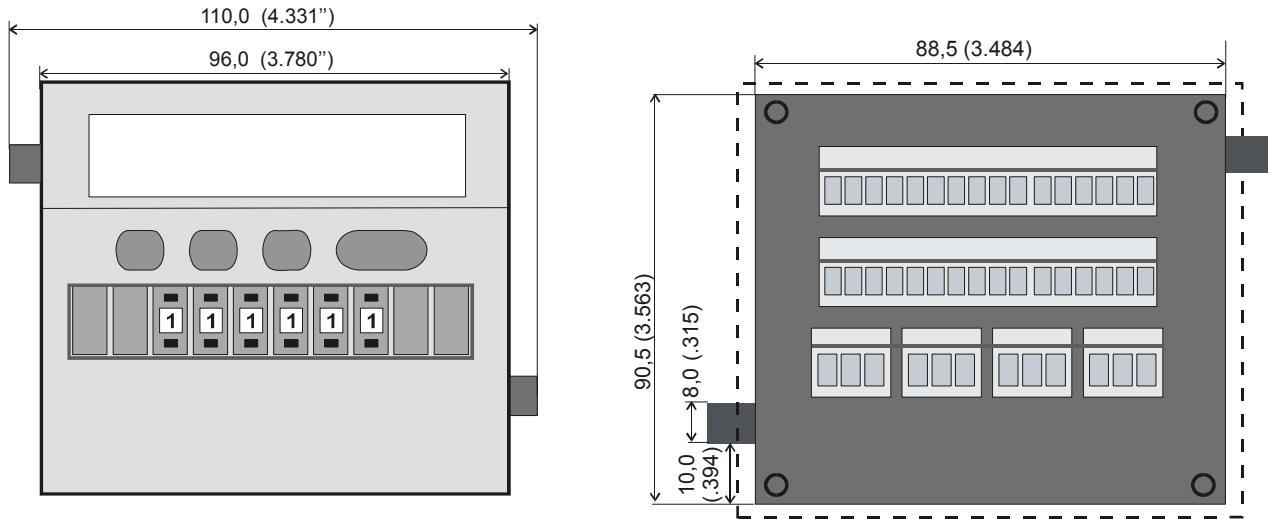

**With optional plexi glass cover
 for protection class IP65
 (motrona part # 64026)**

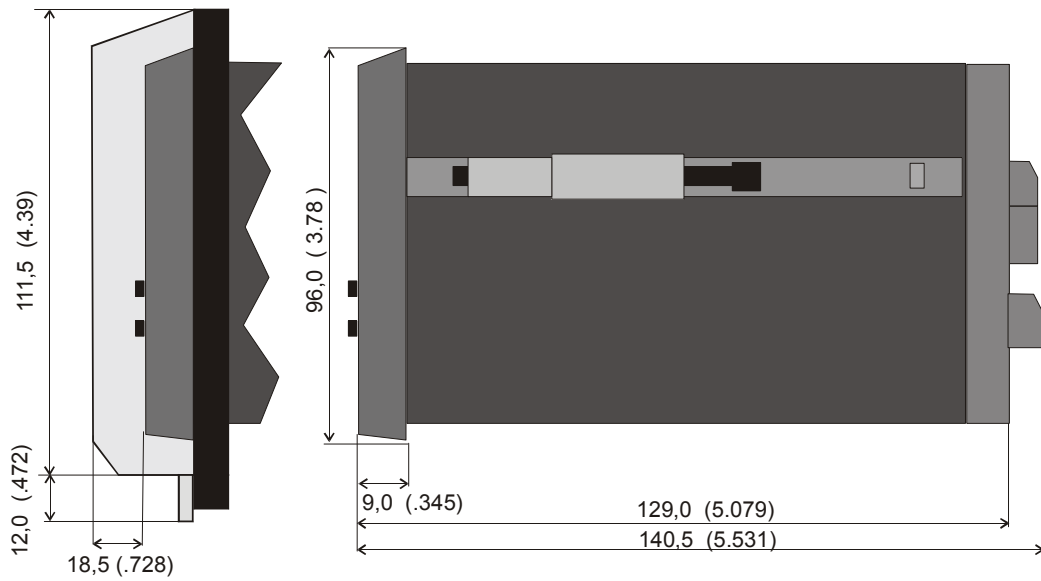

Panel cut out (b x h): 89 x 91 mm (3.504" wide x 3.583" high)