



BY 125

Low Cost Synchrocontroller Operating Instructions for Operator Software OS3.x



- 80 kHz counting frequency
- Highly dynamic response (120 μ sec)
- Positional synchronisation and ratio control
- Marker pulse and print mark registration
- Speed transitions by S-shape profile
- TTL encoder inputs (A, \bar{A} , B, \bar{B} , Z, \bar{Z})
- Easy PC setting via serial link, data loading on the fly
- EEPROM and RAM memory
- Simple to mount (rack or DIN rail)
- Standard version suitable for all 4-quadrant type drives with a \pm 10 volts speed input
- Option UP125 especially suitable for 1-quadrant type inverter drives with positive speed input only and digital direction select inputs

Table of Contents:

1.	Introduction	Page	3
2.	Principle of Operation	Page	3
3.	Impulse Scaling	Page	6
4.	Ratio Change During Operation	Page	8
5.	Change of Phase and Relative Position	Page	8
6.	Index Registration and Control (Modes 2 and 6)	Page	9
7.	Connections and Hardware Settings	Page	10
	7.1 Power Supply	Page	11
	7.2 Encoders	Page	12
	7.3 Analogue Input and Output	Page	13
	7.4 The Serial Ports	Page	13
	7.5 Control Inputs and Outputs	Page	15
8.	Register List and Clarification	Page	17
9.	The Front LED	Page	23
10.	Analogue Signal Guide	Page	24
11.	Digital Signal Guide	Page	24
12.	Remarks about Encoders, Drives, Cables etc.	Page	25
13.	Steps for Commissioning	Page	28
14.	Hints for Final Operation	Page	32
15.	Serial Codes	Page	35
16.	Master Reset and EEPROM Erasure	Page	35
17.	Specification and Dimensions	Page	35
18.	Appendix: Option UP125 for use with 1-quadrant inverter drives and digital direction select inputs	Page	37
19.	History	Page	37

These instructions have been written and checked to the best of our knowledge and belief. However, MKS will not be liable for errors and reserves the right for changes at any time without notice.

1. Introduction

The BY 125 is a cost-effective synchroniser for high performance synchronisation and registration applications between two independent drives, with a convincing value for price ratio. The units are suitable for any kind of drives (AC, DC, Servo etc.) that are variable in speed under control of a 0-10 volts speed reference. The 80 kHz counting frequency allows use of high-resolution encoders even with high operation speeds. Due to the very short response time of 120 µsec only, the unit also provides a proper synchronisation under highly dynamic conditions with servo drives.

When on the slave site you use a 1-quadrant-type drive (speed reference always with positive polarity 0...+10 volts), and your drive uses digital forward/reverse select inputs, please see "Option UP125" and observe the special hints given in section 18 of this manual.

As a matter of course, full ratio control and other functions like index pulse tracking, print mark registration and remote phase control are included in the wide set of standard functions.

All settings are fully digital and no potentiometer adjustments are necessary. Programming of parameters is accomplished by PC/Laptop, using our **operator software OS3.x** (CD included in delivery). Remote control is possible by serial communication, i.e. with use of one of our operator terminals TX720 or TX340. Where parallel BCD data must be used for remote control, our parallel-to serial- gateway CA125 is applicable.

The mechanical construction uses a closed 19" steel cassette with all connections on its front. Rack mounting of the cassette therefore does not require use of a swivel frame.

Use of our **SM 150 back plane** (option) also allows easy DIN rail mounting.

The BY 125 operates from an un stabilised 24 VDC supply (18 V... 30V).

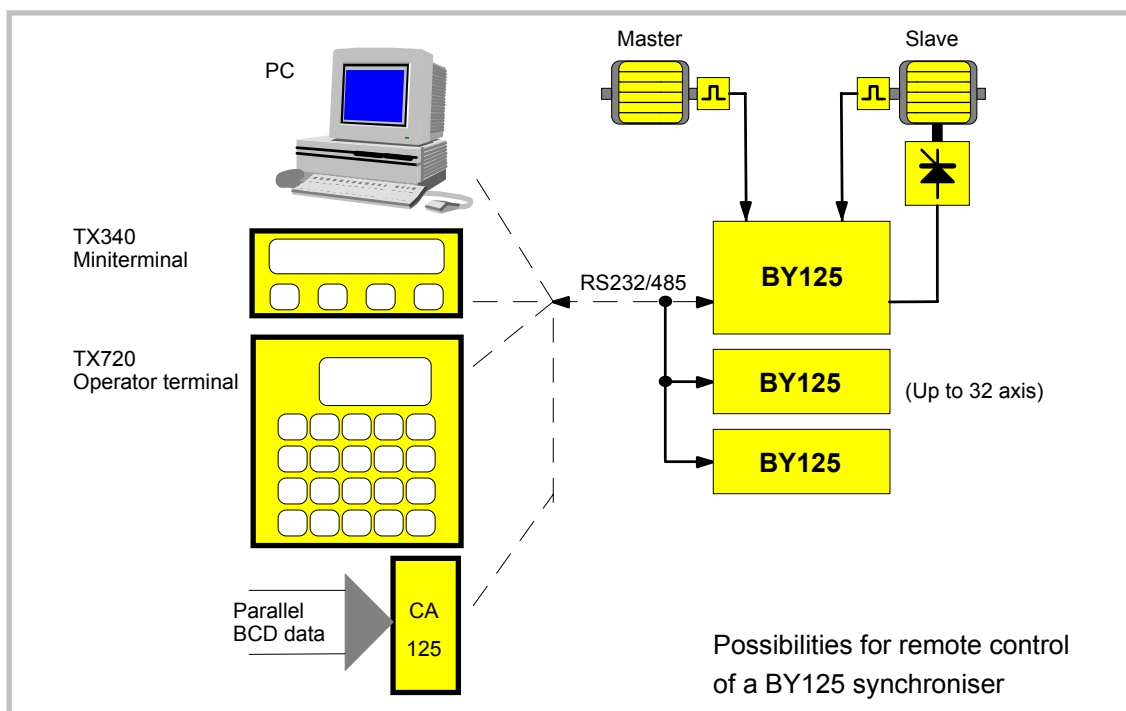

2. Principle of operation

All operation is based on setting an "analogue synchronisation" between the drives first. This can be achieved by feeding a common speed reference voltage to the drives and tuning the drive speeds in order to get them into an approximate synchronism. A ratio adaption may be necessary for the Slave drive, as shown in figure 1. This analogue pre-synchronisation can match the two speeds within an error range of approx. 1%.

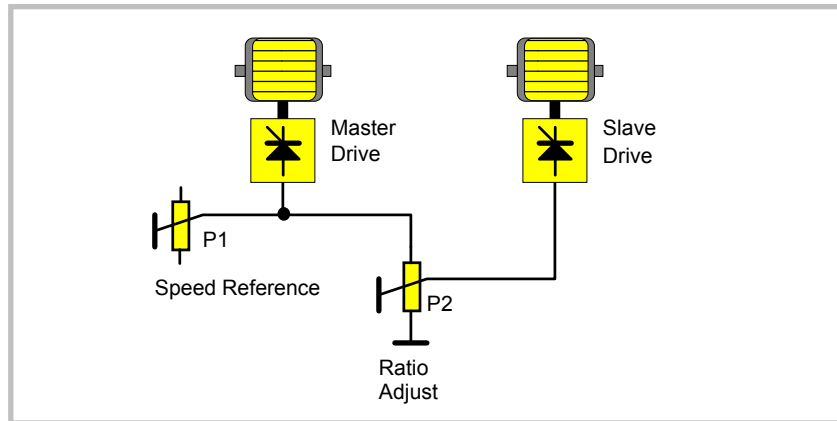

Fig. 1

The digital synchronisation now has to compensate for the analogue speed errors in order to get an **absolute**, **angular** and **positional** synchronisation with **no drift** and no cumulative displacement of the motor shafts. This needs a digital feedback of the angular shaft position of the drives. In general, incremental shaft encoders or equivalent signals (e. g. encoder simulation from a resolver system) are used.

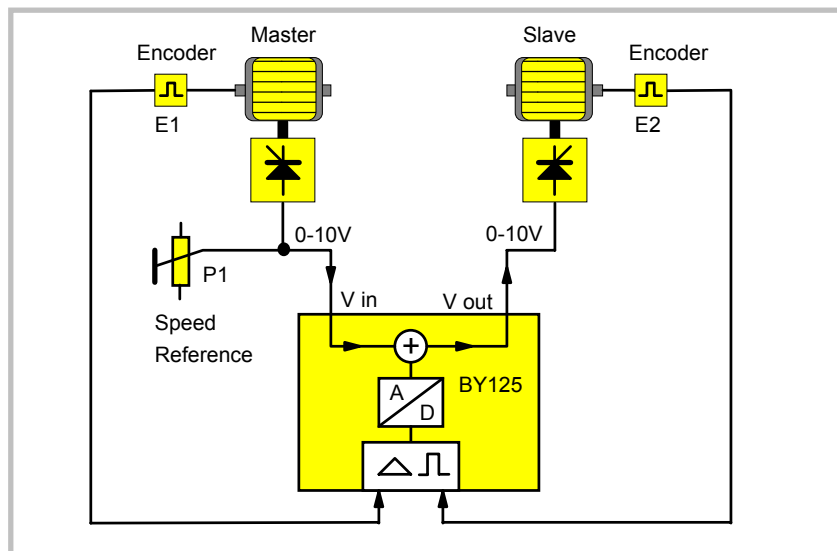

Fig. 2

The synchroniser continuously checks the two shaft positions and immediately responds by an analogue correction signal when an angular error starts to appear. This analogue correction, added to the slave's reference with the correct polarity, will keep the shaft positions of Master and Slave in line. As the synchroniser responds within only microseconds to each individual encoder pulse, the slave will practically have no chance to drift away.

Fig. 2 shows that a feed **forward signal** "Vin" is needed to run the drives, and a correction voltage is added to receive the total slave speed reference "Vout". It is easy to understand that the feed forward signal must be proportional to the master speed. There are three ways to generate Vin:

- a) Use of the master speed reference voltage, like shown in Fig. 2. This presumes the master drive does not use any remarkable internal ramps, because otherwise Vin would not represent the real master speed upon acceleration or deceleration. As a result, procedure a) must only be used when the master speed reference already includes the ramp (generated by a PLC output etc.) and the drive's internal ramp is set to zero or it's minimum value. However, a real speed analogue signal from a tacho generator can be used at any time. Analogue feed forward should only be used when replacing older existing BY125 units against a new one.

- b) Use of the frequency- to- voltage converter installed in the BY125 units.
This procedure can be used for most of all applications.

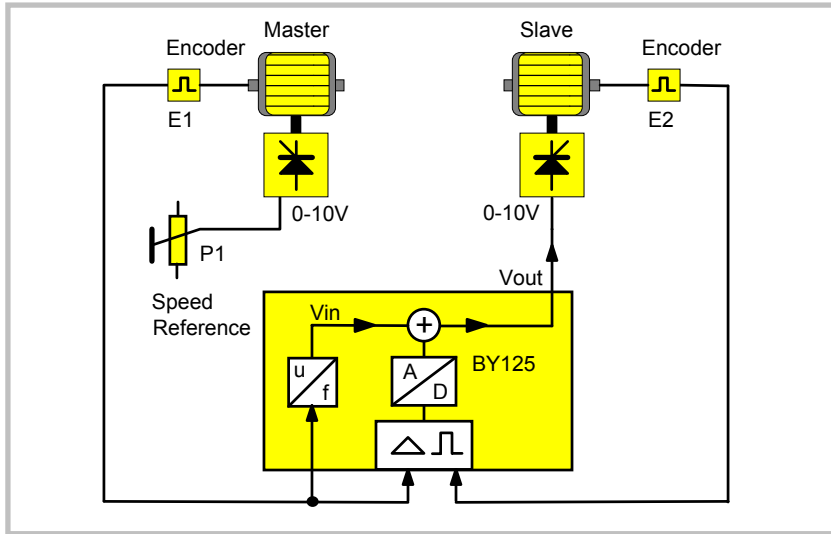

Fig. 3

The feed forward signal now is generated internally from the frequency of the master encoder and no external voltage must be applied to the analogue input. This allows the master drive to use internal ramps, because the encoder frequency always represents the real actual speed of the master.

Also, procedure b) allows the "Master" to be just a measuring wheel with encoder, and not really a drive.

Digital feed forward like shown here operates fine for encoder frequencies higher than 500Hz at maximum speed. Lower frequencies at maximum speed may result in slight instability of the synchronisation.

- c) Use of an external voltage- to- frequency converter
 This procedure is used only exceptionally.

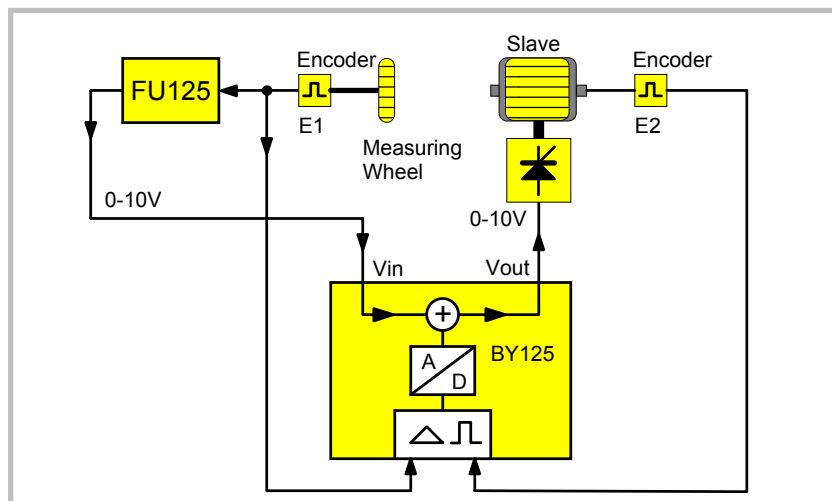

Fig. 4

With use of our ultra fast precision converter type FU125, also extremely low frequencies will cause no problems.

The mode of generating the feed forward signal can be selected by the register "LV-Calculation".

3. Impulse Scaling

For easy adaption of the synchroniser to operational and physical conditions (gear ratios, encoder resolution, roll diameters etc.), both, Master and Slave impulses can be scaled separately. The scaling factor "**Factor 1**" provides impulse scaling for the Master channel and the scaling factor "**Factor 2**" does the same for the slave.

Both factors are 5 decade and operate in a range from 0.0001 to 9.9999. Setting them both to 1.0000 will result in a 1:1 speed and phase synchronisation. The factors can be set via **serial link**, using the **RS232** or the optional **RS485** interface (Ordering number **SS124**).

Independent of the way of factor setting, the slave always changes its shaft position in respect to the master according to the following formula:

$$S_{\text{Slave}} = \frac{\text{Factor 1}}{\text{Factor 2}} \cdot S_{\text{Master}}$$

(Proportional operation)

$$S_{\text{Slave}} = \frac{1}{\text{Factor 1}} \cdot \frac{1}{\text{Factor 2}} \cdot S_{\text{Master}}$$

(Reciprocal operation)

Proportional or **reciprocal** operation can be selected by the parameter "**LV-Calc**" in the Setup menu.

Remarks to previous formulae:

When **positional** and **angular synchronisation** is required, we recommend to set S_{Master} and S_{Slave} to a number of encoder pulses received from the encoders when both drives move a defined synchronous distance or one defined machine cycle forward. When only **speed synchronisation** is needed (i.e. speed errors in a range of 10^{-5} can be accepted), S_{Master} and S_{Slave} can also be set to the encoder frequencies at synchronous speed.

For a normal, proportional operation, under consideration of all geometrical machine data, one would try to fix up the value of Factor 2 in a way to have Fact1 directly in "User units". (Factor 1 is the parameter that could be changed during production, and Factor 2 is a "machine constant" that normally will never be changed).

The following example should explain the calculations for Factor 1 and Factor 2 with a feed roll system, where the tension of the material should be varied remotely by adapting the slave speed:

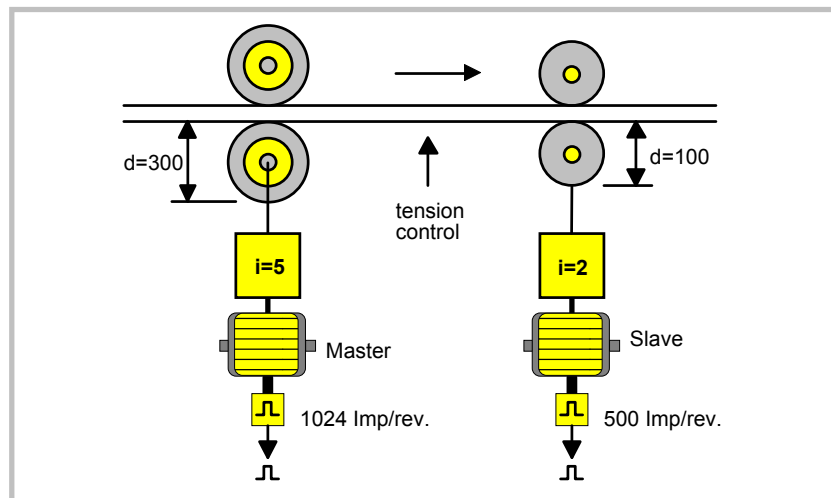

Fig. 5

With one full revolution of the master must roll, we receive $5 \times 1024 = 5120$ impulses from the master encoder. If the material must pass the roll **without** any tension, the slave roll would exactly need three revolutions at the same time. So we will get $3 \times 2 \times 500 = 3000$ impulses from the slave encoder. This means, we need **3000 slave pulses for every 5120 master pulses** to operate synchronously.

We subsequently have to set up Factor 1 and Factor 2 so, that the relation

$$5120 \times \text{Factor 1} = 3000 \times \text{Factor 2}$$

becomes true. The simplest way to do this, is to set the factors exactly to the digital value of the impulse numbers from the opposite side, i. e. Factor 1 = 0.3000 and Factor 2 = 0.5120. Then, the synchronous condition will absolutely match the formula, **but** there could be little comprehension from the operator, that he needs to set a value of 0.3000 on his terminal to have tension-free synchronism. He would understand more clearly, if the setting were 1.0000.

So, we need to use the formula with different figures:

$$5120 \times 1,0000 = 3000 \times \text{Factor 2}$$

As a result we find that Factor 2 must be $5120 : 3000 = 1.7067$. This setting calibrates the Factor 1 to comprehensible "user units" (1.0000 = no tension, 1.0375 = 3,75% tension). The same result can be achieved when using the parameter "F1-Scaling Factor" to scale the values transmitted from the operator terminal.

Hint 1: It is best, whenever possible, to have Factor 1 and Factor 2 in a numeric range of 0.1000 - 2.0000. This allows the BY to use the full 12 Bit resolution of all D/A converters. When, for example, the factor calculation results in figures like 4.5000 and 7.8000, it is better to set 0.4500 and 0.7800 (or 0.9000 and 1.5600 or any other proportional values within the recommended range) to ensure best operation.

Hint 2: Whenever a **positional synchronisation** is needed, cumulative errors must be avoided by proper factor setting (factors can only be set with 4 digits to the right of decimal point). If, i.e., a ratio of 16 : 17 would be required, never use the decimal expression of 0.94117647... as Factor 1, because the non-entered digits will accumulate to give positional errors after a short time. This can be completely avoided when using factors like 1.6000 and 1.7000 (or also 0.8000 : 0.8500 etc.).

This hint need not be observed with **speed synchronisation** alone, because speed errors will remain undetectable small.

Hint 3: It is best to choose the ppr number of the encoders to receive frequencies in approx. the same range on both sides. It can i.e. become difficult to synchronise 100 Hz on one side with 80kHz on the other side.

4. Ratio Change During Operation

The speed ratio can be changed at any time by changing Factor 1 via serial link. Changing Factor 1 from 1.0000 to 2.0000 will result in double slave speed. The **speed transition** can be sudden or soft. The slave approaches its new speed via an adjustable **sin² ramp**. See parameter "**Ramp1**".

When using operation **mode 4**, the speed ratio, can also be changed via remote **push buttons** or PLC signals. In this mode, any activation of the „Index Master“ and „Index Slave“ hardware inputs will cause Factor 1 to continuously increment or decrement. Upon release of the Trim command, the latest scaling factor will be responsible for the speed ratio.

The speed of incrementation / decrementation can be set by the register "Trim Speed". At any time, the operative scaling factor can be stored to the EEPROM by hardware signal or software command. This facility ensures later use of the same speed ratio, also after power down.

To avoid wrong operator settings or exceeding of given limits, Factor 1 range can be limited by the parameters Factor 1 Minimum and Factor 1 Maximum.

5. Change of Phase and Relative Position

The relative phase situation between Master and Slave is normally set by the state upon power-up or with the last Reset signal (in index modes, the index edges and the programmed phase displacement define the relative position, see chapter 6.)

During all the operation, this initial phase condition is held without any errors, unless the operator uses one of the following facilities to change this condition:

5.1 **Timer Trimming (Modes 1 - 4 and 8)**

This function, activated by the "Trim +" and "Trim -" inputs, provides a temporary higher or lower slave speed which results in a phase displacement between the motor shafts. When releasing the trim buttons, the drives will synchronise again in their new relative position. The **differential trim speed** is generated by an internal timer and is adjustable. It operates as a speed addition or a subtraction to the slave, **without consideration of the actual absolute speed**. This is why the trim function can also be used at standstill, to move the slave into a convenient start-up position.

5.2 **Impulse Trimming (Modes 5 and 6)**

The "Trim +" and "Trim -" inputs accept external pulses from a pulse generator, encoder or a PLC. Every pulse applied to one of the Trim inputs will shift the phase exactly one encoder pulse forward or backward. This procedure provides repeatable changes or adjustment of the phase situation between the drives, e.g. under control of an external impulse counter or a PLC. Modes 5 and 6 can also be used to realise the function of a differential gearbox.

5.3 **Phase Offset Operation (Mode3)**

The unit provides an Offset register, which can be set to a desired number of encoder impulses. Every rising edge at the "Index Master" input will displace the actual phase forward by the number of offset impulses, and every rising edge at the "Index Slave" input will do the same to the other direction. By this function, the phase situation can be stepped forward or reverse by the pitch set to the offset register.

6. Index Registration and Control (Modes 2 and 6)

Index or marker pulses are used to automatically set the drives or the material into a correct relative position. It is possible to **either** use the zero pulse inputs on the encoder terminals (Z and \bar{Z} , 5 VTTL) **or** the index inputs on the screw terminals (10...30V), and register "Index Mode" selects which inputs are in use.

It is possible to enter the phase displacement between the marker pulses by PC or host computer, and to change it at any time, at standstill or on the fly (Register "Phase offset").

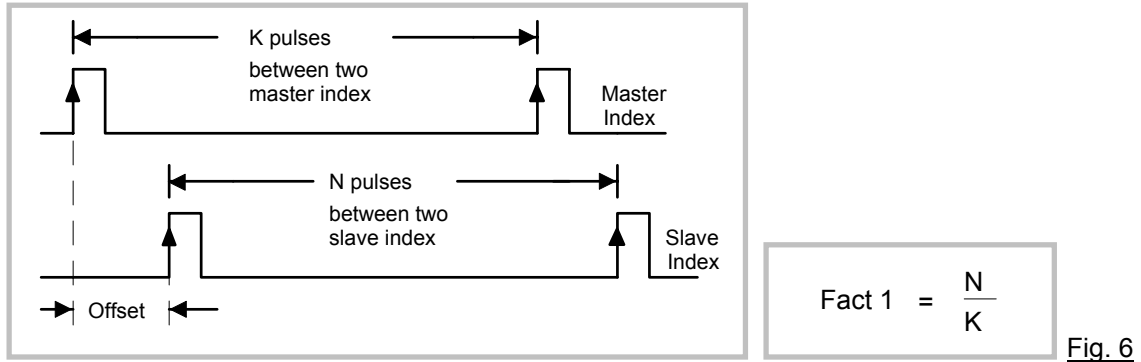

Fig. 6

The parameter **Factor 1** is used to align different impulse numbers **K** and **N** on both encoders. The number of slave impulses **N** must be set to register "Impulse Index".

The formula Fig. 6 shows how to calculate Factor 1. The offset needs to be set directly as "number of slave impulses" and has a setting range from -N to +N which means -360° to +360° of displacement.

Between two marker signals, the drives operate in a normal digital synchronism. The master impulses are scaled with **Factor 1**, but the slave impulses count with a **fixed factor of 1,000** in Index mode.

A positive edge on the slave index input starts a phase comparison with the previous master index and a correction, if not coincident to the offset **M**. **Additional phase adjustment**, as described under sections 5.1 and 5.2, is also possible in index mode. I. e., starting from an initial phase position, the final **phase** can be easily **tuned**, by pushbuttons or PLC, if applicable. The new phase can be restored to the phase offset register by a store command.

As a special, the BY 125 can even operate with **different number of marker pulses** on both sides. This is possible due to the following features:

- a. The master index input is equipped with a programmable index divider, which, for example, allows sampling of only each fifth marker pulse.
- b. The slave index input is locked in a way, that it is active only once after each valid master marker pulse.

This enables the user, in terms of one machine cycle, to have for example five master markers and three slave markers. Upon start up, the BY 125 checks for the nearest marker couple and sets them in line. Subsequently, each fifth master index will be checked with each third slave index.

Operation mode 8 provides a fully unlocked function of the index inputs and every couple of marker impulses will cause a correction, no matter if the master leads the slave index or vice-versa.

This mode needs setting of a "maximum index error" to the "Impulse Index" register (setting in slave encoder increments). The differential speed to correct for the index error can be set by register "Trim speed".

Mode 8 is perfectly suitable for compensation of wheel slip with large cranes (reference marks on the rails, see special description "Version B25") and to equalise different distance between products when passing from one conveyor to another.

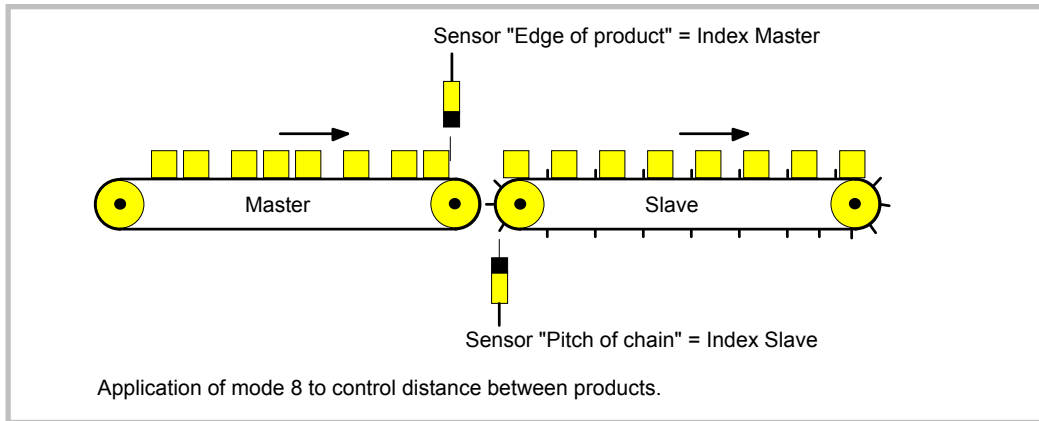

Fig. 7

7. Connections and Hardware Settings

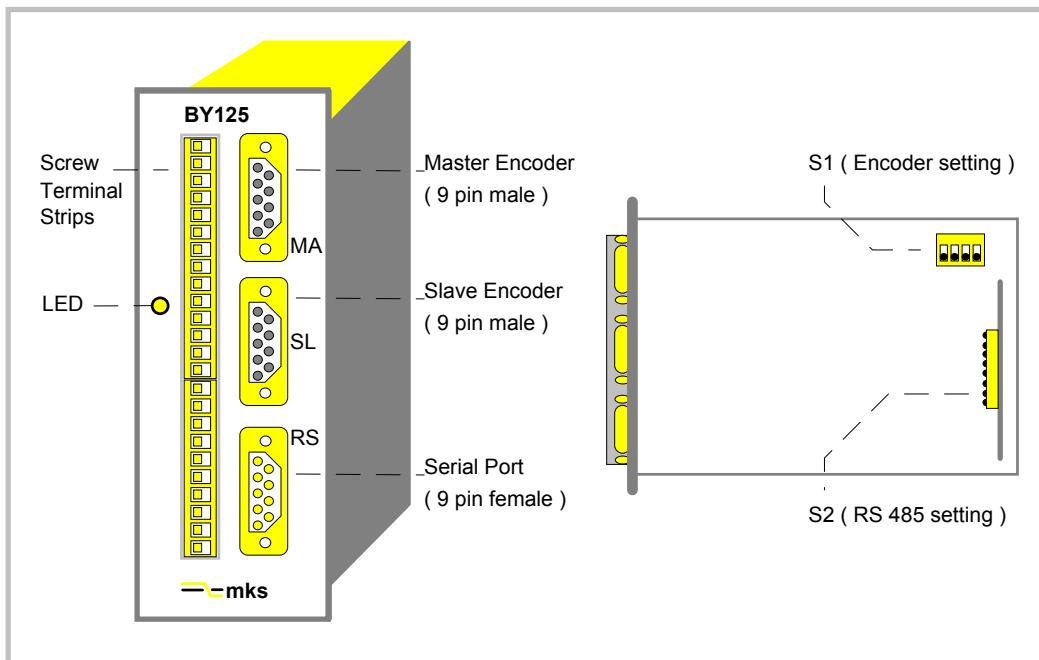

Fig. 8

Fig. 8 shows the connectors available on the front plate, Fig. 9 shows the block diagram of the unit with its minimum peripheral configuration and Fig. 10 shows the screw terminal assignment.

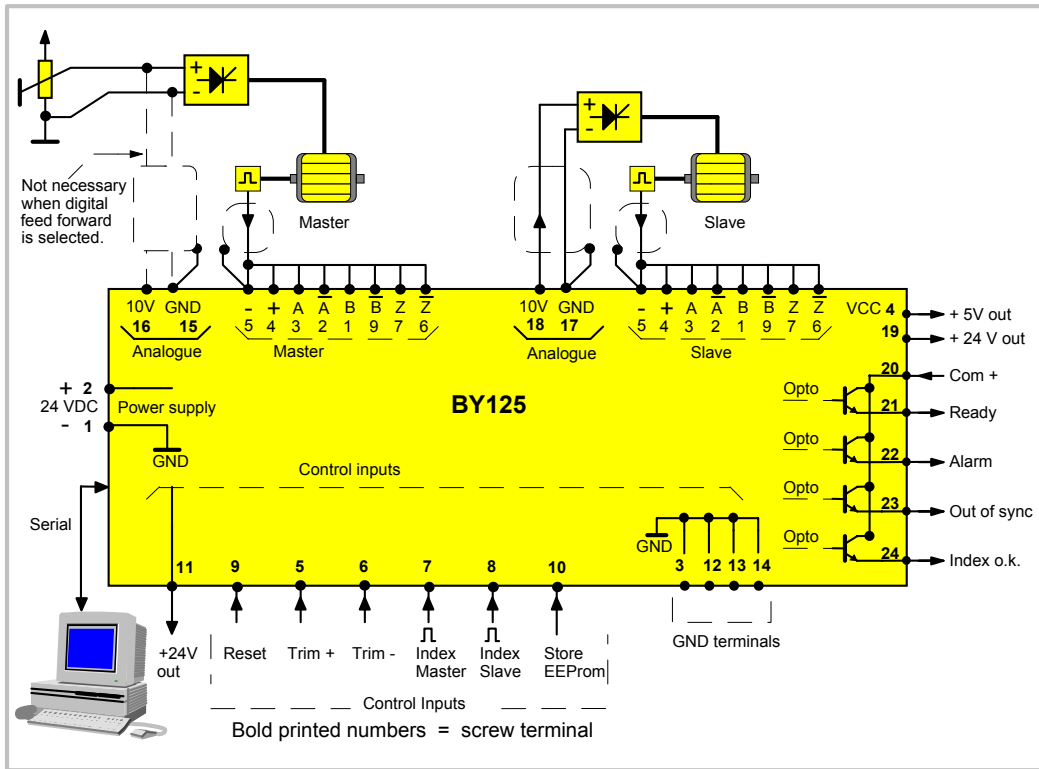

Fig. 9

7.1 Power Supply

The BY 125 operates from an unstabilised 24 VDC supply (+/- 25%); however, the voltage including ripple should not exceed the following limits (18 V...30 V). The supply of the BY 125 is electrically protected against wrong polarity misconnection by protection diodes.

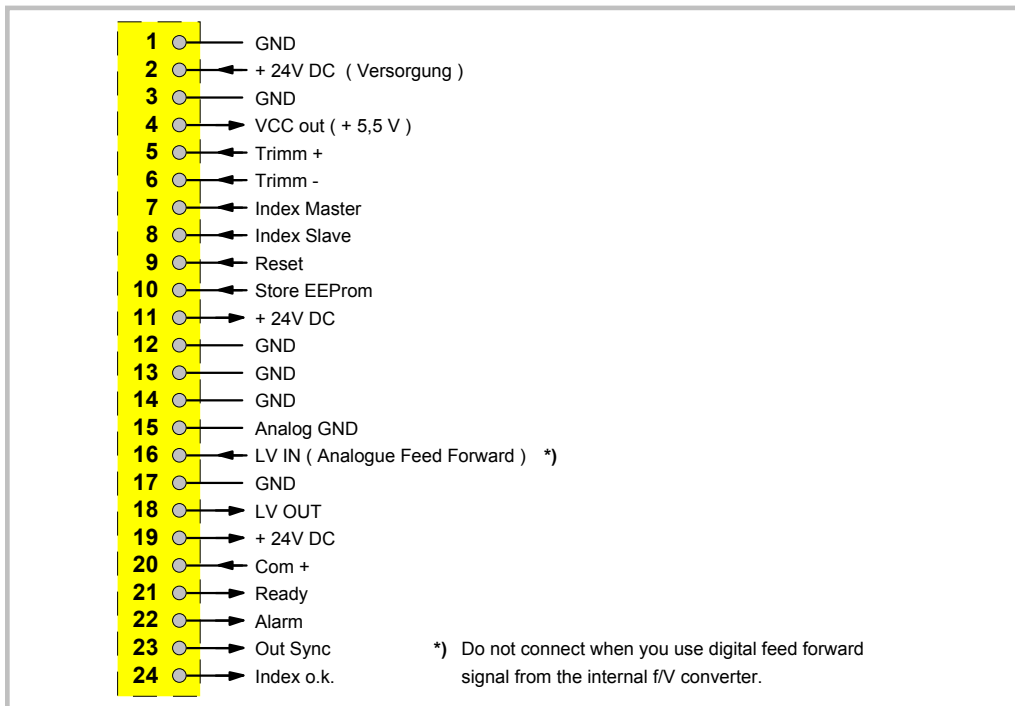

Fig. 10

7.2. Encoders

The unit only accepts 5V RS422 pulse signals or similar signals from an encoder simulation of a drive. It is essential to connect the channels A, \bar{A} , B, \bar{B} . The zero input channels Z and \bar{Z} can be omitted, if not needed.

An auxiliary voltage of **5,5 V (max. 500 mA total)** is available on the connector plugs **"Master"** and **"Slave"**, for easy supply of the encoders. Both connectors on the unit are Sub-D-9 pin, male.

Where you find you are working with existing 10-30 Volt encoder signals that feature only A, B and Z signals, the PU 202 converter should be used to gain full complementary signals in line with RS422 standards. Against special order designation, BY125 units can also be delivered with HTL encoder inputs: Option HTLIN1 provides inputs A, B, Z with 24V level (inverted channels not connected) and option HTLIN2 provides all six channels including the inverted ones with 24V level. With these options, the 24V power supply of the unit is connected to master and slave encoder connectors to supply the encoders.

Fig. 10 and Fig. 11 show the encoder connections and the principle of the input circuit. When connecting the encoders it is not too important to wire the A and B signals to produce the correct counting direction. The direction can be determined in the setup menu.

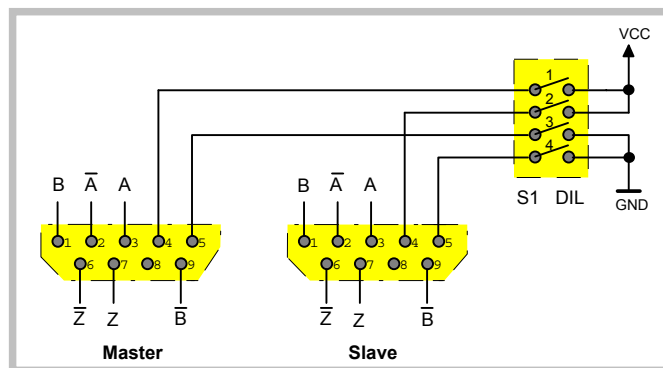

Fig. 11

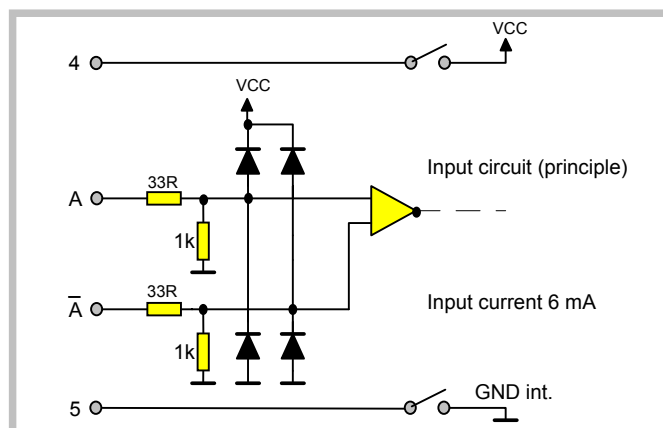

Fig.12

For screening, please refer to section 12.3

Important

The 4-position DIL switch S1 allows the desired encoder voltages to be set. See Fig. 8.

- **With encoders, supplied by the BY 125:**
Set positions 1 and 3 to "ON" (Master)
Set positions 2 and 4 to "ON" (Slave)
Connector pins 4 and 5 provide the encoder supply.

- **With encoders**, supplied by an **external source**, or when an **encoder simulation** from the drive is used:
Set position 1 to "OFF" and position 3 to "ON" (Master)
Set position 2 to "OFF" and position 4 to "ON" (Slave)
Use connector pin 5 as common GND potential.
- For **fully differential** operation:
Set positions 1 and 3 OFF (Master)
Set positions 2 and 4 OFF (Slave)

The inputs then operate in differential mode, which is best in terms of noise immunity. However, the impulse source must be of line driver type with external supply, when this input mode is used.

Warning:

When switch positions 1 and 2 are "ON", you must ensure that no supply is applied to pins 4 and 5, as this will cause serious damage within the unit.

7.3. Analogue Input and Output

The analogue input and output signals can be found on screw terminals 16 and 18. **The Analogue common GND is internally connected to the minus of the 24 VDC supply. All analogue levels are in range +/- 10 Volts.**

LVin (Terminal 16): Receives a voltage proportional to the master speed e.g. master reference voltage or line tacho signal (+/- 10 V range), when you use analogue feed forward. **Remains unconnected when you select digital feed forward.**

LVout (Terminal 18): This output supplies the slave with its speed output reference voltage. When the **"Gain Corr"** is set to any value except 0, the digital correction voltage is superimposed to this output.

7.4 The Serial Ports

Delivery always includes a RS232 interface. Also an additional RS485 interface is available (option SS 124). Both serial links use the same connector for wiring and serial communication is possible with both interfaces at a time in an alternating sequence (dialogues must not overlap).

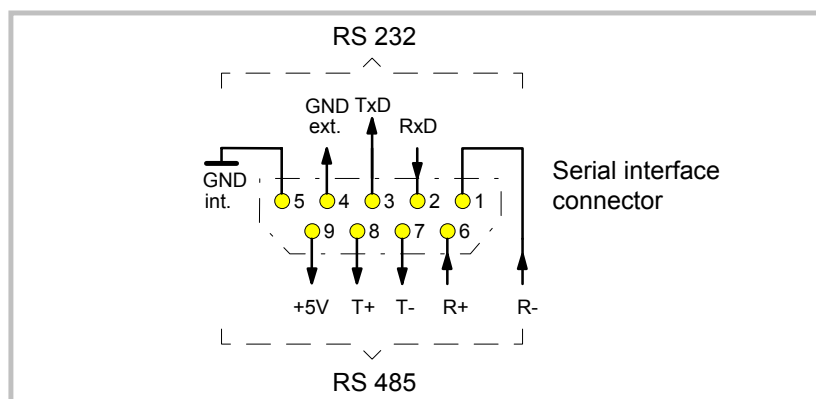

Fig. 13

The serial link **must** be used

- For PC set-up of the registers upon commissioning, using our operator software OS3.0.

It **can** be used

- For full on-line operation with a master computer, accessing all registers and control functions. The serial communication protocol uses the **Drivocom** standard (ISO 1745), which is widespread in drive industry.

Before running the BY125 with an **RS 485 bus**, some adjustments are necessary. Open the right hand side plate. The optional RS 485 interface card with the 8-position DIL switch S2 is located at the right-hand side of the main board (see Fig. 8).

The desired bus type and potentials can be set there.

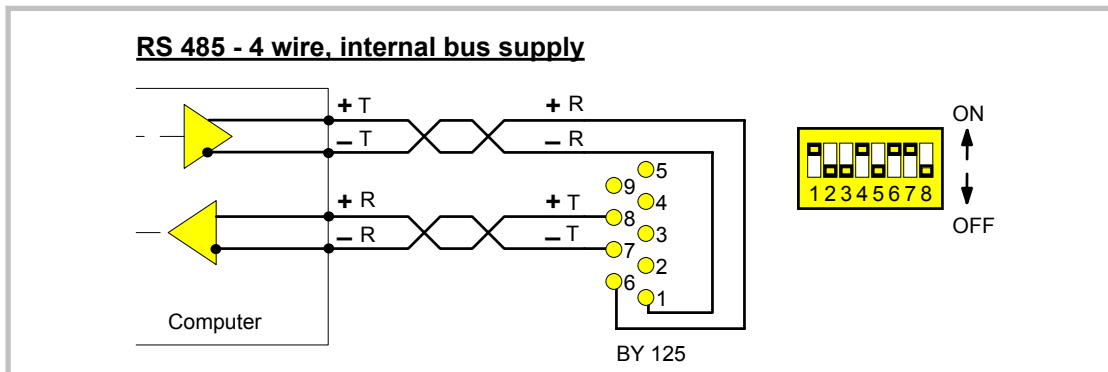
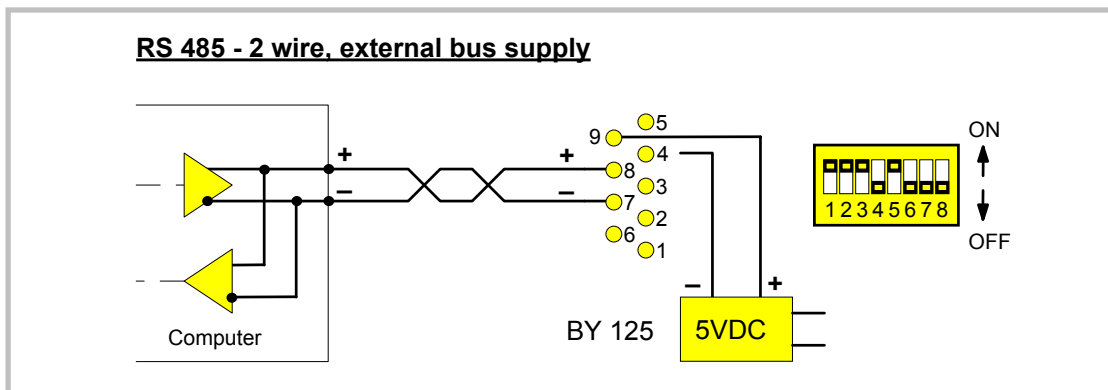
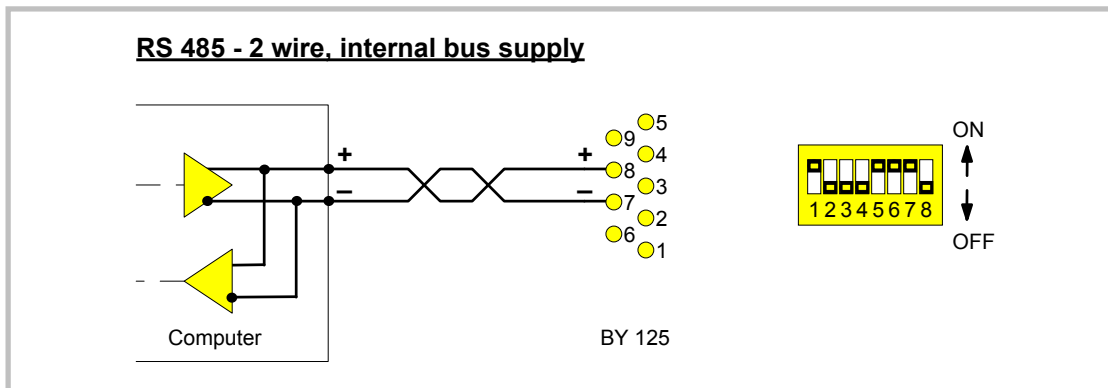

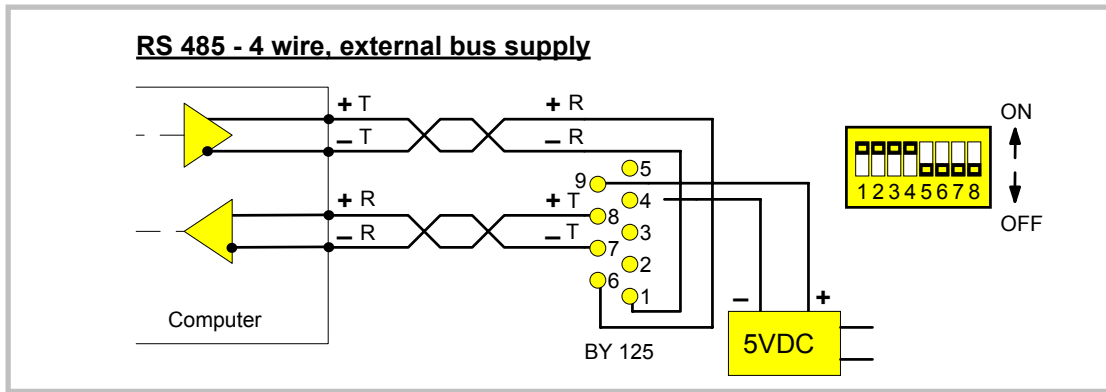

Remarks:

- When using RS485 transmission, the BY 125 needs time to switch from "transmit" to "receive" and the computer must provide a delay like shown in table 14 prior to the next serial access.
- With internal RS 485 bus supply, never an external voltage must be applied to pins 4 and 9 of the connector!

Delay Times:	
Baud Rate:	Time in ms:
600	32
1200	16
2400	8
4800	4
9600	2

Fig. 14

7.5 Control Inputs and Outputs

There are 6 control input lines and 4 control output lines available on the screw terminals.

All inputs are fully PLC compatible. All signals refer to GND and the minus potential of the supply.

All the outputs are opto-isolated transistor outputs that are also PLC compatible.

Logic 0 (low) = 05 Volts
Logic 1 (high) = 1830 Volts

To avoid command latch errors, the command signal must stay in a stable state for at least 1 ms.

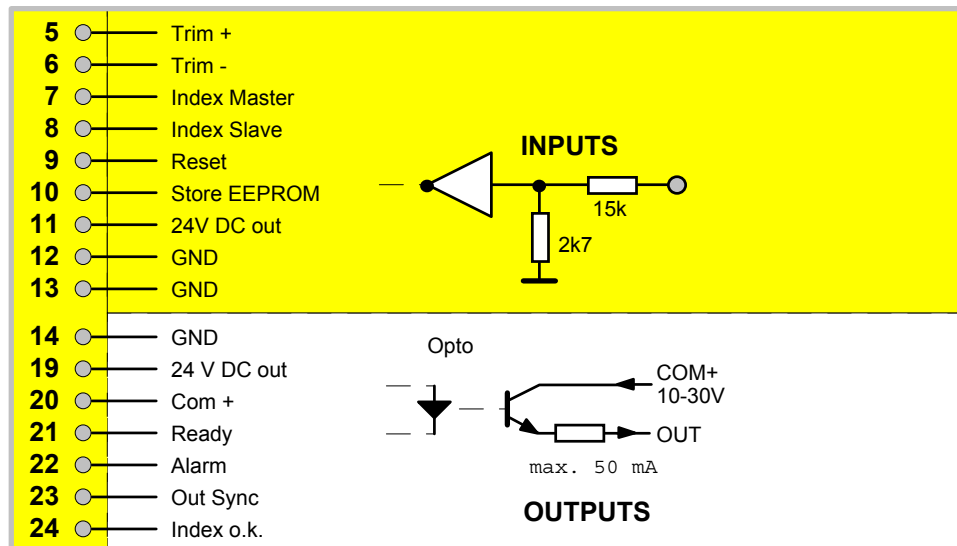

Fig. 15

Inputs:

Trim+ (5) : Adjusts the angular position of the slave to lead the master, in the chosen direction, like described in section 5.1 and 5.2.

Trim- (6) : As above but adjusts the slave to lag the master.

Index Master (7), Index Slave (8) : These 10-30 V inputs allow the use of marker pulses from proximity switches or photocells, when the encoder index pulses are not suitable. The inputs are edge-triggered (positive transition) and must be enabled by the "Index Mode" register. With mode 4, the index inputs are used to increment or decrement Factor 1.

Reset (9) : Sets the internal differential counter and the analogue correction signal to zero. Both drives run solely in analogue synchronisation whilst held.

Store data to EEPROM (10) : A rising edge on this input will store all actual operating data to the EEPROM and upon next power-up the data set will be available again. **The BY 125 is out of operation for a time of 30 ms after activation of the store command and the Ready output will be low while storage is in progress.**

Control Outputs:

Ready (21) : This announces that the unit is ready to run. On power up, this output is "Low" for about one second to allow the power supply to settle, and then switches to "High". The output goes low also for the duration of parameter storage to the EEPROM.

Warning:

When "High", the unit could not detect a system fault itself, but this is not a guarantee for fault-free operation!

- Alarm (22)** : The alarm output signals that the preset tolerance band has been exceeded in one direction or the other, as specified by the parameter "Alert".
- Out Sync (23)** : This output goes high when, despite of full analogue correction, the synchronisation can no more be maintained. Mechanical or electrical problems can cause this situation (e. g. current limit of the drive).
- Index o.k. (24)** : When High the slave index pulses are inside the window set by parameter "Index Window", with respect to the position of the Master index pulse and the phase displacement set to register "Phase Offset".

8. Register List and Clarification

The register set is held on an EEPROM. **The registers can only be programmed via serial link, using the RS232 or RS485 interface.**

The Software OS3.2 (included with delivery) allows easy downloading of complete register sets, reading, copying and editing the parameters.

It includes also an adjust- and test-program for easy set-up and commissioning.

The subsequent table shows all operational registers. Remarks "C00", "C01" etc. indicate the appropriate serial access codes. All parameters, with respect to their numeric values, are internally limited to their permitted range. Register marked with * are only operative when you select one of the index modes.

Data in		Setup	
C00	Factor 1	C40	Mode
C01	Factor 2	C41	LV Calculation
C02	Trim Time	C90	Unit NR.
C03	Integration Time	C91	Baud - Rate
C04*	Impulse Index	C92	Serial Form
C05*	Offset	C45	Master Direction
C06	Alert1	C46	Slave Direction
C07	Ramp	C47	Offset Correction
C08	Stop Ramp	C48	Gain Correction
C09	Correction Divider	C50	Gain Total
C10*	Phase Adjust		
C11*	Index Divider		
C12	F1 Scaling Factor		
C13	Factor 1 Minimum		
C14	Factor 1 Maximum		
C15*	Index Window		
C16	Sampling Time		
C17*	Index Mode		

Fig. 16

8.1 Data In Registers

- Factor 1** : Impulse scaling factor for the master encoder. Range 0.0001 - 9.9999
- Factor 2** : Impulse scaling factor for the slave encoder. Range 0.0001 - 9.9999. In modes 2, 6 and 8, this setting is automatically replaced by a fixed 1.0000 scaling.

Trim Time : Rate of change, to be entered as a number of software cycles (1 cycle = 100 μ sec), for phase trimming, when the +/- trim inputs are activated, or for Factor 1 inc. / dec. in mode 4.
Range of setting: 001 - 999 cycles per increment.

Example:

With Trim Time set to 001, each 100 μ sec the phase will be displaced by one encoder increment (= 10 000 increments each second), and with Trim Time set to 050, the processor will take 50 cycles = 5 ms. for one increment.

Integration Time : Time constant for the phase integrator, which avoids positional errors, is also to be entered as a number of software cycles. Range 000 - 999
Setting 000: No integration, proportional control only

Setting 020: Integrator needs 20 cycles (= 2 ms) to compensate for one increment etc.

With all index modes, the integrator should be switched off (set Integration Time = 0), because the index corrections will eliminate positional errors.

Impulse Index * : Number N of pulses between slave markers (see 6.).
Range 1-999 999

Offset * : Number of slave encoder pulses that the slave should displace in respect to the master. With index modes, this is the offset between the rising edge of the master index and the rising edge of the slave index. With mode 3, this is the pitch of phase displacement with each rising edge.

Alert : Set tolerance window. Can be set between 0000 - 9999 bits of difference. Typical setting 30. Affects the Alarm output when out of tolerance. Please observe that the alarm count considers the error bits after the correction divider (see setting of register "Correction Divider").

Ramp : Ramp time for changes of speed ratio. Range 0 - 99,99 s. Setting Ramp to zero results in abrupt change of the slave speed. All other settings provide a \sin^2 transition from one ratio to next within the preset time, independent of the difference between initial and final speed.

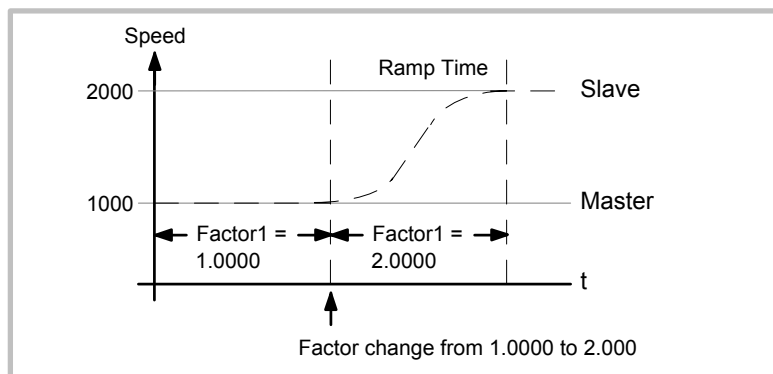

Stop-Ramp : When during full operation the Test- Program is activated by serial command, the slave drive will use this ramp to slow down prior to executing the test functions. Range 0 - 99,99 s.

Correction Divider : This setting function is active in all operation modes. Setting range 1-9. This provides a digital attenuation of the phase correction signal that is produced, when the drive on mechanical grounds (dead band or backlash) cannot respond. In such a case, it is not desirable to make corrections immediately. The "Correction Divider" provides a window for the drive "backlash", within which the controller produces no correction and a division of the differential error count.

Value 1 = No window, Reaction to 1 error increment, no division
Value 2 = Window +/- 1 Encoder increment and error division :2.
Value 3 = Window +/- 3 Encoder increments and error division :4.
Value 4 = Window +/- 7 Encoder increments and error division :8.
Value 5 = Window +/-15 Encoder increments and error division :16
etc.

Phase Adjust * : Digital attenuation of the response upon marker pulse errors.
1 = full correction with each index check, i.e. 100%
2 = correction by several steps with 50% of the residual error
3 = correction by several steps with 25% of the residual error
4 = correction by several steps with 12.5% of the residual error
5 = correction by several steps with 6.25% of the residual error
etc.

Clarification:

The setting depends on the dynamics of the drive and the maximum speed.

Example: If a marker pulse arrives every 20 ms but the drive cannot correct the largest error in 20msec, then it will lead to instability, if the next correction is performed before the previous is completed. In such a case the phase correction percentage must be reduced.

Index-Divider * : This is a programmable index divider for the master marker pulses, permitting different numbers of marker pulses from the master and the slave. See Section 6. Range 1 - 99. For the same reason as clarified above, we also recommend to use the divider with marker pulse frequencies higher than 10 Hz.

F1-Scaling Factor : This factor allows scaling of the remote Factor 1 entry to "**user units**" or to adapt the numeric value of Factor 1 to the application. It is **essential**, for all steps of set-up, to program **F1-Scaling Factor** to **10000** first in order to avoid confusions with factor calculations. **Only with this value, the setting corresponds to the real operative Factor 1!**

Once the set-up procedure is terminated, set F1-Scaling Factor to the numeric value that later should correspond to an operative value of 1.0000 for Factor 1.

Example: If the operator desires to set 3.5000 instead of 1.0000, set F1-Scaling Factor to 35000. For all factor calculations, please be aware if you operate with a proportional or a reciprocal characteristic of Fact1!

Factor 1- Minimum :
Factor 1 Maximum : These are limitations of the setting range of Factor 1 and out of range settings will be overwritten by the appropriate min or max value. With Factor 1 Minimum set to 0.9500 and Factor 1 Maximum set to 1.0500, the operator is limited to a +/- 5% variation of the speed ratio. In mode 4 the inc. / dec. range of Fact 1 is limited to this window.

Index Window * : This parameter sets a window, where the master and slave index pulses should be within during operation. It is possible to set the value in a range from 1 to 9999 encoder increments. It affects the output “**Index o.k.**” when master and slave index pulse are out of range.

Sampling Time : Sets the internal f/V converter (digital feed forward control) in respect to dynamics and resolution. Setting is uncritical. Lower set values result in faster response, but less accuracy of the feed forward signal. Higher set values result in better accuracy, but slower response with sudden speed changes.
Please note: Feed forward signals with lower accuracy do not at all affect speed accuracy of the synchronising process, but only might cause slight angular errors. Depending of the maximum master encoder frequency, the subsequent setting can be recommended:

fmax	Sampling-Time (recommended)
1 kHz	100 msec
3 kHz	33 msec
10 kHz	10 msec
30 kHz	3 msec
100 kHz	1 msec

Index Mode* : Selects the source of the index pulse individually for the Master and Slave side, where HTL means a Z signal with 18...30Volt level on screw terminal input and TTL means a Z / \bar{Z} signal with TTL level at the Sub-D-encoder input plugs.

Index Mode	Slave index source	Master index source
0	HTL, terminal 8 on screw terminal strip	HTL, terminal 7 on screw terminal strip
1	TTL, index pins 6 and 7 at Slave input	HTL, terminal 7 on screw terminal strip
2	HTL, terminal 8 on screw terminal strip	TTL, index pins 6 and 7 at Master input
3	TTL, index pins 6 and 7 at Slave input	TTL, index pins 6 and 7 at Master input

8.2 Setup Registers

Mode : The mode setting determines the function of the Trim inputs and the Index inputs. There are 8 modes available like shown in Fig.16



Mode	Trim inputs	Index inputs	Impulse scaling
1	Phase trim by internal timer 	No function	Fact 1 : Fact 2
2	Phase trim by internal timer 	Index control with phase offset 	Fact 1 : 1,0000
3	Phase trim by internal timer 	Index Master $\int =$ Forward offset displacement Index Slave $\int =$ Reverse offset displacement	Fact 1 : Fact 2
4	Phase trim by internal timer 	Index Master  Increment Fact 1 Index Slave  Decrement Fact 1	Fact 1 : Fact 2
5	Phase trim by external pulse source 	No function	Fact 1 : Fact 2
6	Phase trim by external pulse source 	Index control with phase offset 	Fact 1 : 1,0000
7	Similar to Mode 1	Similar to Mode 1	Similar to Mode 1
8	Phase trim by internal timer 	Unlocked index registration for special applications	Fact 1 : 1,0000

Fig.17

LV-Calculation : This parameter determines the relationship between the factor settings and the resulting slave speed. Also it selects analogue or digital feed forward operation.

With settings 1 - 4, an analogue signal proportional to the master speed must be applied to terminal 16.

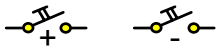
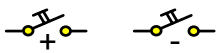
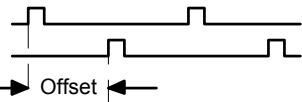
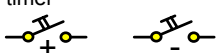
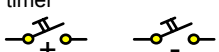
Settings 5 - 8 are similar to 1 - 4, but the feed forward signal is generated by the internal f/V converter and terminal 16 must remain unconnected.

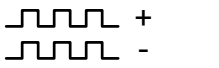
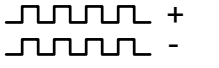
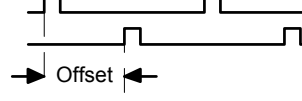
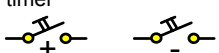
LV-Calc = 1 : The slave speed changes **proportionally** to the Factor 1 setting, i. e. doubles motor speed when changing Factor 1 from 1.0000 to 2.0000. This setting is suitable for the majority of all synchronising applications.

LV-Calc = 2

: The slave speed is **reciprocal** to the Factor 1 setting, i. e. halves the motor speed when changing Factor 1 from 1.0000 to 2.0000. This setting is suitable for rotating cutter applications (Factor 1 represents the length preset) and all other applications where the engineering units are reciprocal to the motor speed.

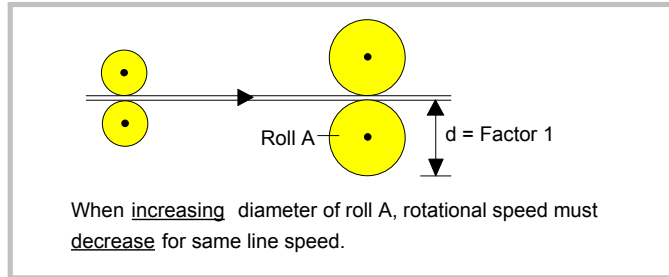

Fig. 18

LV-Calc = 3

: The slave speed changes **proportionally to Factor 1** and **reciprocally to Factor 2**. Suitable for various applications that need remote setting of both scaling factors.

LV-Calc = 4

: The slave reference voltage remains constant, independent of Factor 1 and Factor 2 settings.

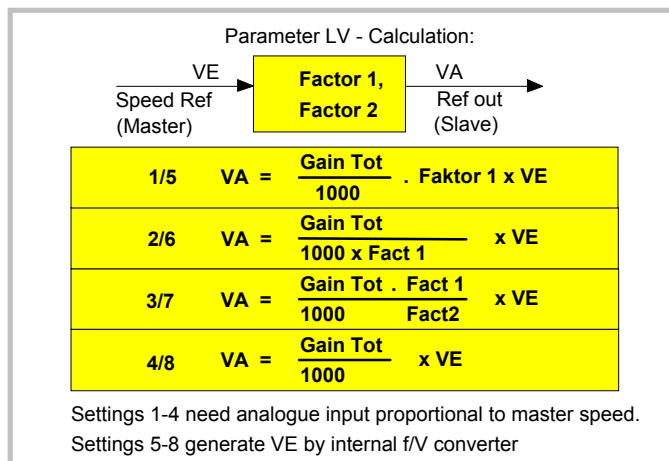

Fig. 19

Clarification

When LV - Calc is set to 1, the output voltage will be equal to the input voltage with Fact 1 = 1.0000 and Gain Tot = 1000.

Unit-Nr

: Allows entry of a serial device address between 11 and 99. It is not allowed to use addresses containing a "0" (i. e. 20, 30, 40 etc.) as these are reserved for collective addressing of several units.

Factory setting: 11.

Baud-Rate

: The following transmission rates can be selected:

0	9600 Baud
1	4800 Baud
2	2400 Baud
3	1200 Baud
4	600 Baud

Fig. 20

Factory setting: 0.

Ser-Form : The following formats of serial data can be selected:

Ser-Form	Databits	Parity	Stopbits
0	7	Even	1
1	7	Even	2
2	7	Odd	1
3	7	Odd	2
4	7	None	1
5	7	None	2
6	8	Even	1
7	8	Odd	1
8	8	None	1
9	8	None	2

Fig. 21

Factory setting: 0.

Mast Dir : Direction of phase of the master encoder. Setting 0 or 1. See commissioning.

Slav Dir : Direction of phase of the slave encoder. Setting 0 or 1. See commissioning.

Offset Correction : Digital setting of analogue offset on correction signal. Setting range +/-99. Normal setting "0".

***) Remark:** BY125 uses precision instrumental amplifiers that do not need an offset adjustment. In larger drive plants however, by balance currents between several devices, an external offset can build up, which can be compensated by the offset adjust. Also, offset setting can be used to compensate for dead band with AC inverter drives.

Gain-Correction : Digital setting of gain control (proportional control) Range 0 - 9999. Setting to 9999 results in a response of 100 mV per error bit. Recommended setting: 200...2000 (i. e. 2mV...20mV per error bit).

Offset Total : Not used. Set to 00 at any time.

Gain-Total : Digital setting of multiplication of analogue voltage signal. Range 0 - 99999.

With analogue feed forward, the output voltage is

$$V_{out} = \frac{\text{Gain Total}}{1000} \times \text{Factor 1} \times V_{in} \quad (\text{Volts})$$

With digital feed forward, the output voltage is approximately

$$V_{out} = \frac{f_{\text{master}}}{5400} \times \text{Gain Total} \times \text{Factor 1} \quad (\text{Volts})$$

Where f_{master} is the frequency of the master encoder in kHz. Please note, the output voltage swing is limited to +/-10 Volts max.

9. The Front LED

The LED on the BY125 front side indicates the operating condition of the unit. When all operation is o.k. the LED is flashing slowly. With any other kind of LED state, the unit indicates hardware or software fault.

10. Analogue Signal Guide

The following block diagram shows the full internal treatment of the analogue line signal and the registers involved.

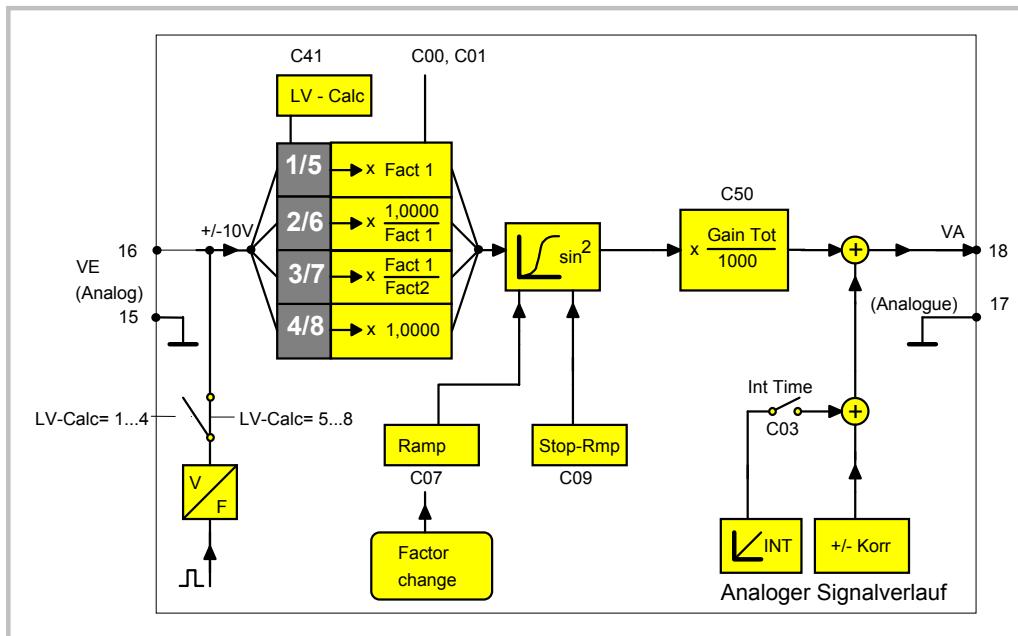

Fig. 22

11. Digital Signal Guide

The following block diagram refers to all essential impulse processing necessary to generate the analogue correction signal. For easier comprehension, unimportant details have been omitted.

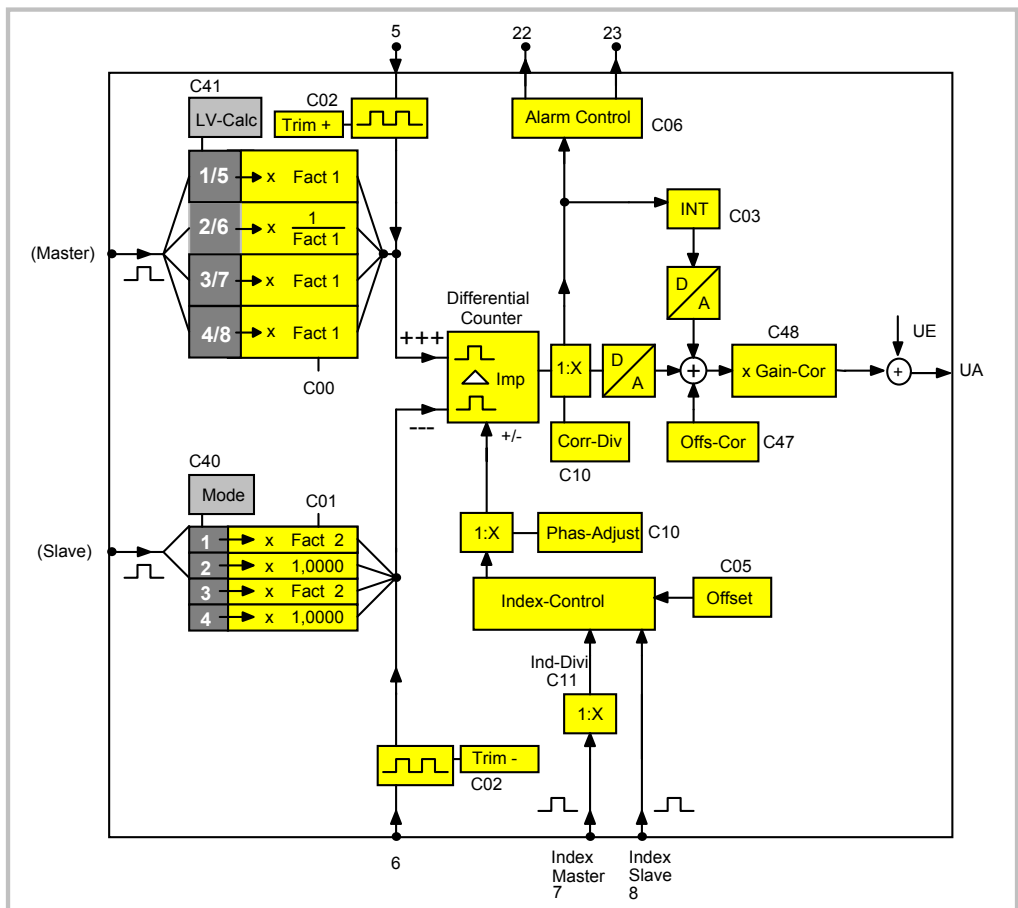

Fig. 23

The master and slave impulses pass individual impulse scaling circuits (dependant on the LV-Calc and Mode registers) before getting to a differential counter. The differential counter receives a final scaling by the Corr-Div register. A 12-bit DAC converts the error bits to analogue. Prior to passing the total error gain adjust, the integrator result and an offset are added.

The integrator basically represents an auxiliary counter that automatically increments or decrements, unless the differential error count would be within a window of +/- 7 error bits. The integration count is limited to a +/- 512 counting range. A final scaling by the Gain-Cor register provides adaption of the correction voltage to the line reference voltage.

The count inputs of the differential counter receive supplementary impulses from the phase control circuit, in order to enable phase adjustment and displacement. The index control circuit also can preset the differential counter, which, under internal timer control, will always clean up the error and phase conditions.

The total analogue correction output can be calculated as follows:

$$\text{Korr} = \frac{\Delta \text{ Imp}}{\text{Corr- Div}} \times \frac{\text{Gain-Cor} \times 10 \text{ mV}}{1024} \quad (\text{ m V })$$

An analogue saturation comes up with 1024 error bits, but the counter itself will memorise and compensate for up to 32000 errors bits.

12. Remarks about Drives, Encoders, Cables etc.

12.1 The **drives** in use must be dimensioned correctly with respect to power and dynamics required. **The BY 125 can never provide synchronisation outside the physical limits of the drives.** Prior to connecting the master and the slave to the synchroniser, they must be adjusted for a proper stand-alone operation with no oscillation, by means of a remote speed reference voltage. The reference inputs must be potential free. The Minus input may be tied to protection earth. In this case, avoid ground loops, i. e. by the power supply source that might be grounded also. The reference inputs must never be at mains potential!

12.2 The resolution of the TTL-**encoders**, in principle, should be as high as possible (observe maximum frequency!), in order to keep the mechanical phase error as small as possible when the synchroniser "plays" a few encoder increments around the zero error position. Normal phase errors are in a range of five encoder increments and the encoder resolution determines what the mechanical result is. However it would be nonsense to choose the number of ppr much higher than needed or reasonable. If, for example, a gearbox with several 0.1 mm of clearance is installed, a 0.01 mm resolution of the encoder could cause stability problems, which needed to be removed by the "Corr-Div" error divider again. Please choose ppr numbers of master and slave encoders in a way that encoder frequencies are in the same range. This ensures that the unit can use full analogue resolution.

The BY 125 loads each encoder channel with a current of 6 mA. Though some encoder types are able to supply the impulse inputs of several synchronisers at a time, we recommend using our impulse splitter type GV 150.

It was designed for applications, where several target devices must be feed from one encoder and the unit is cascable up to any number of outputs. Where you find the total load of impulse channels exceeds the max. current specified by the encoder manufacturer, it is mandatory to use the GV150 splitter!

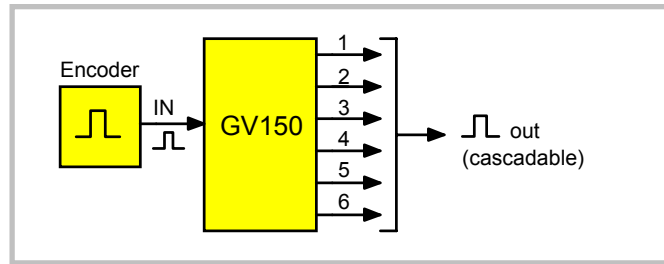
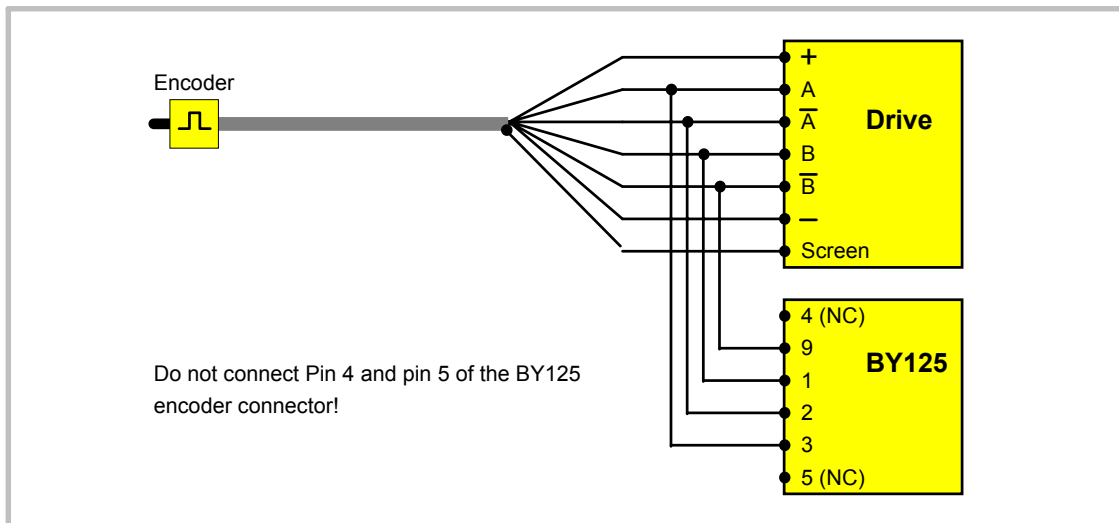

Fig. 24

Warning:

Where you use **one common encoder** for feedback of the drive and feedback for the BY125 at the same time, there may come up interference problems. You can use a GV150 impulse splitter to eliminate any kind of problems. In most applications, the common encoder would also work fine when it is supplied by the drive and the BY125 operates in fully differential mode like shown.



12.3 Screening: It is mandatory to use screened cables for encoders and analogue signals. Correct connection of the screens is **essential** for trouble-free function. Control inputs like Reset, Trim etc. can be unscreened, provided the cable length does not exceed 5 meters. Use screened cables for longer length also.

The following basic screening rules must be observed:

- a. With impulse cables (encoders), the screen must be connected at both ends.
- b. Analogue signals and control lines need screens connected only on one end.
- c. The screen potential must be the internal GND of the BY125 unit (not earth potential! See GND terminals on terminal strip). Since, in general, the minus wire of the 24V power supply will be earthed anyway, the screens will automatically receive earth potential when connected to GND.
- d. At its peripheral end, the screen **must never** be tied to earth nor touch metallic parts that are earthed! Where you use an encoder with plug connection, the screen must absolutely not touch the metallic housing of this connector! (With the encoder mounted at the machine, this would be an illegal earth connection).

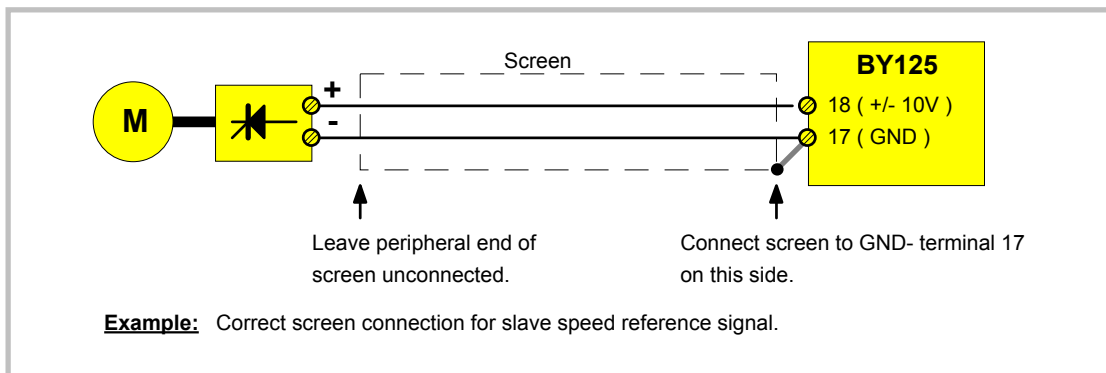
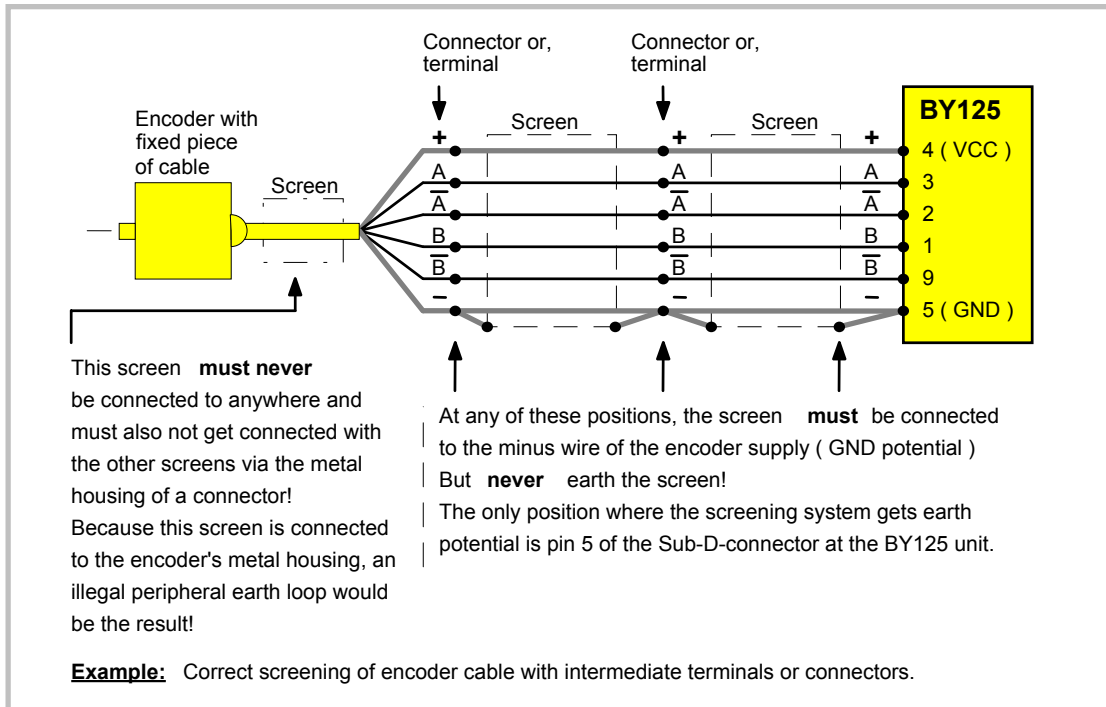

Please note, that **not all types of cables** are suited to transmit frequencies as high as **80 kHz!** However, with proper installation and screening, the RS 422 lines provide perfect transmission even over long distances.

The **cross section** of encoder cables must be chosen with consideration of voltage drop on the line. The BY 125 provides a 5.5 V encoder supply and at the other end the encoder must at least receive its minimum supply voltage! (See encoder specifications).

- 12.4** All cables should be installed separately from motor cables and other power lines. Use normal filtering methods for all inductive equipment installed close to the synchroniser (i. e. RC filters for AC contactors and diodes for DC inductive circuits). Take all precautions in respect to wiring and environment conditions that are usual for industrial electronic equipment.
- 12.5** If you need to switch electronic signals by relay contacts, it is **necessary** to use relays with **gold contacts** (low voltage and micro- currents). For impulse or analogue switching, we recommend the use of our electronic matrix switch type GV 155.

13. Steps for Commissioning

Make sure that the drives are properly adjusted to run the speeds needed for later synchronisation. When using analogue feed forward, the internal acceleration ramps of Master and Slave must be set to minimum. With digital feed forward, the Master may use internal ramps, but the Slave ramps must be set to zero or minimum.

Observe all remarks and hints given in this manual and the drive's manual. In case of any problems, a digital multimeter and an oscilloscope should be available.

- 13.1 Remove right hand side plate and adjust carefully DIL switch S1, as shown in section 7. If a RS485 interface is used, also adjust S2, as shown in section 7.4.
- 13.2 Verify that all connections are correct. Disconnect first all connectors from the front, except the power supply connector. Switch power on. After a short delay, the LED on the front will begin to flash slowly.
- 13.3 Connect your PC to the BY125 unit. The cable you use must be wired like shown.

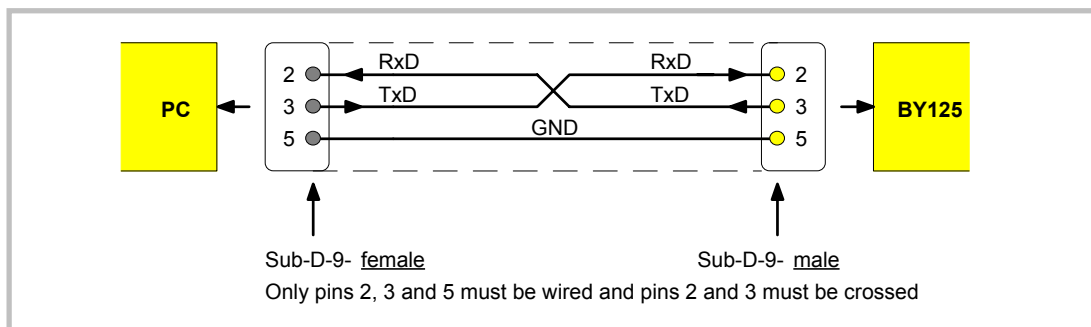

13.4 Start the OS3.0 operator software.

You must see the following main screen now.

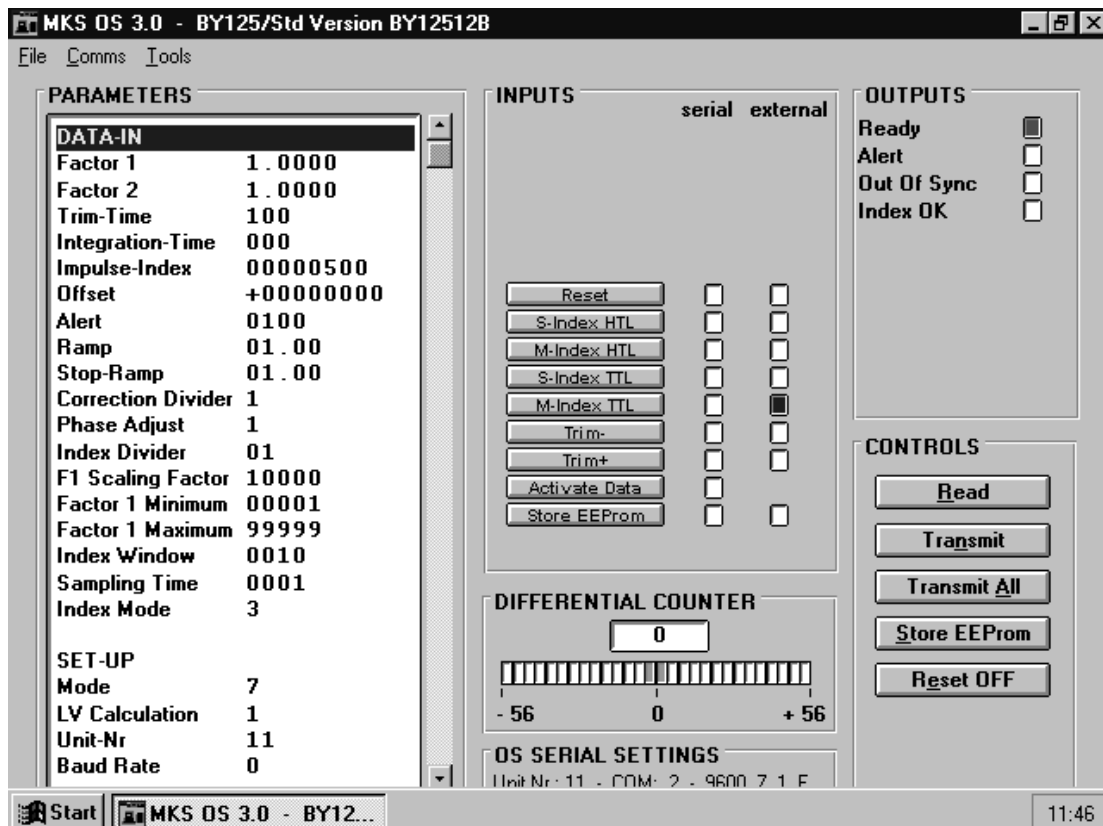

Where you find an empty mask with the indication "OFFLINE". click to the **Comms** menu and verify the serial settings.

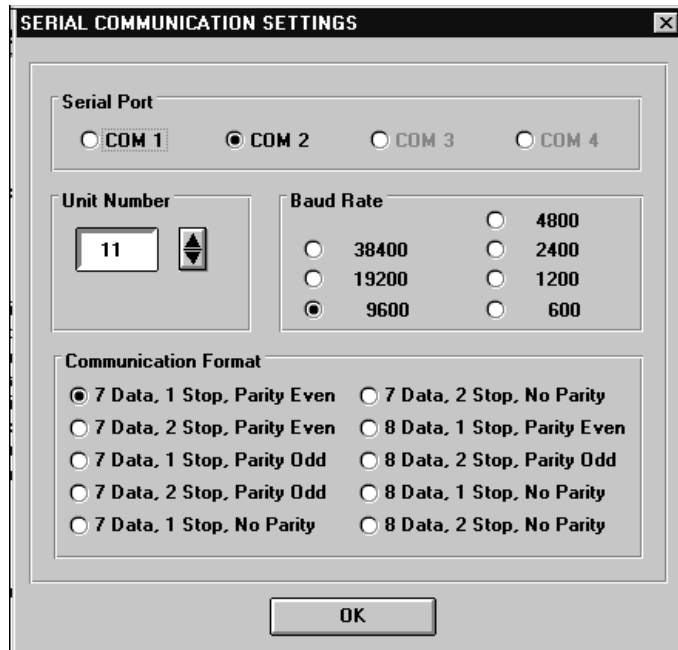

Ex factory, the BY125 is set like shown on the screen and you must set the COM number of your PC which you use for communication. Where you do not know the actual settings of your BY125 unit, you can use the **SCAN** function in the **Tools** menu to find out.

- 13.5** When serial communication is o.k., **enter all variables** according to your application. The following registers must be set to fixed values for the first steps of commissioning, like shown in table. (You can change these settings later when the first steps have been completed successfully).

Integration Time	:	000
Correction Divider	:	1
F1 Scaling Factor	:	10000
Factor 1 Minimum	:	00001
Factor 1 Maximum	:	99999
Mode	:	1
LV- Calculation	:	a) 1 with analogue feed forward b) 5 when you use the internal f/V converter (digital feed forward)
Gain Correction	:	100
Gain Total	:	a) 1000 with analogue feed forward b) see table for digital feed forward

With digital feed forward, the initial "Gain Total" setting depends on the master encoder frequency at maximum master speed:

fmax	Gain Total
1 kHz	54000
3 kHz	18000
10 kHz	5400
30 kHz	1800
100 kHz	540

Settings shown are approximate and values between can be interpolated.

Some other settings are unknown and not important at time this (e.g. Master direction)

When you have entered all variables, click the **Transmit All** button and then the **Store EEPROM** key to transmit and store data to the BY125 synchroniser.

Remark: Where you find letters undersigned, you can get the same function also by keypad, pressing **ALT** and the corresponding key (ex. **ALT** + **S** = Store EEPROM).

13.6 It is recommendable to check the correct function of the external control signals you have connected to the unit. When you switch ON and OFF the remote signals, you can see the input state in the corresponding indicator box of the "external" column of the INPUTS field on your screen.

13.7 With the next step we need to find out the **direction bits** of Master and Slave. At this time we must be absolutely sure about the direction of rotation and our forward/reverse definition.

- a) Where we use analogue feed forward system (LV-Calcaultion = 1...4), the **forward** direction for both, Master and Slave, is the direction which the drives take when **positive speed reference** (o...+10V) is applied.
- b) Where use digital feed forward system (LV-Calcaultion = 5...8), the polarity assignment is not important for the Master. But at any time, the **forward** definition for the Slave is again the direction it moves **with positive speed reference**.
- c) When in later operation no reversals are planned, set up your drives in a way that you **always use positive speed reference**. Where you later need to operate the drives in both directions, make sure you use always the "forward" direction for the following steps (like defined by a) and b).

The subsequent steps will fail upon non-observance!

Select the **Test** function of the **Tools** menu

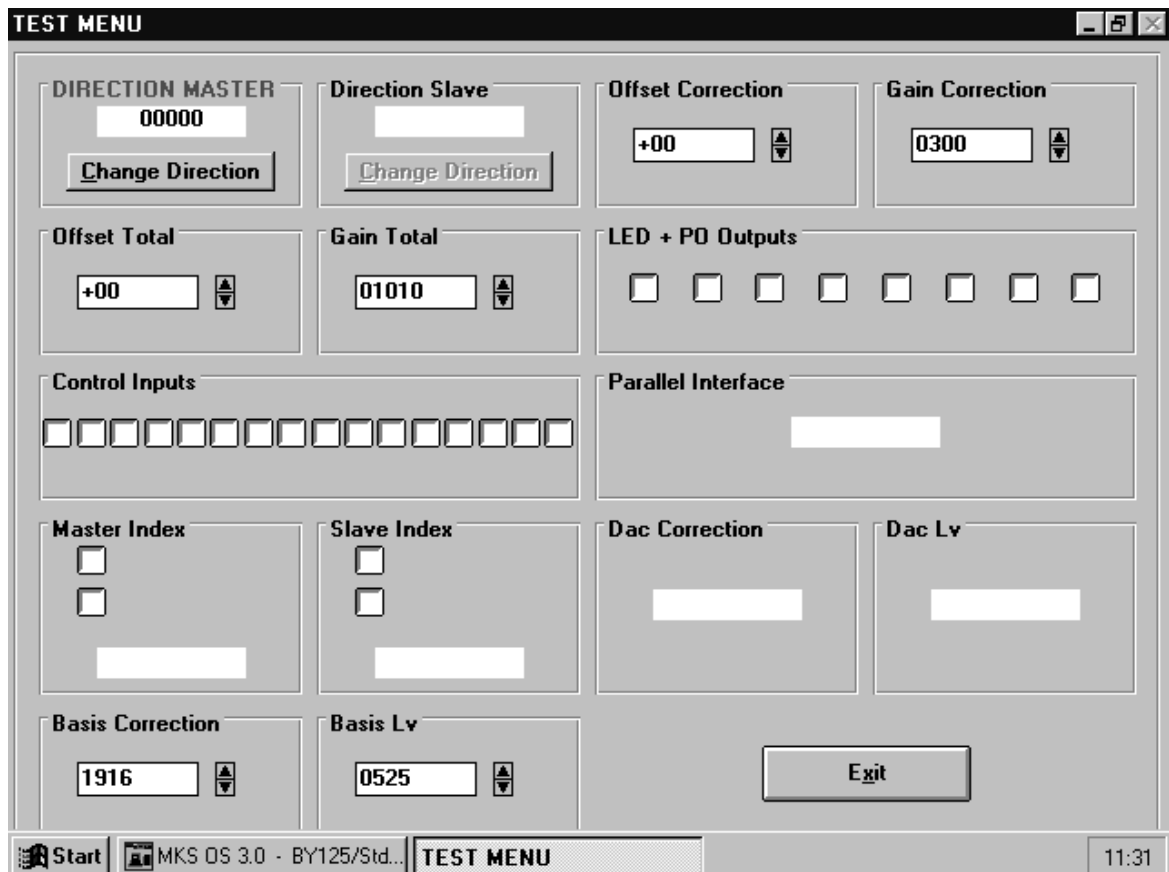

- Click to the "Master Direction" box and you will find an up/down counter for the master encoder. This counter must **count up** (increment) when you rotate the master encoder **forward**. When we count down, click "Change direction" to reverse the counting sense. When we count up, change over to the "Direction Slave" box.
- The "Direction Slave" counter again must **count up** when you rotate the Slave encoder **forward**. If necessary, change direction. When we count up, click to any other box to exit the direction settings.

This procedure has automatically set our Master and Slave direction bits to either 0 or 1 according to need.

Hint: You can use the previous procedure also to check the proper function of your encoders and wiring. While you rotate the encoder forward by exactly one or several turns, we must find the ppr number (or multiple) in our display window. When we rotate back by the same amount, our counter must again have reached zero. Any other result would indicate a problem like wrong wiring of encoder channels or slip of the coupling or interference due to bad screening etc.

13.8 When, in final operation, we do not use one of the Index operation modes, we can **exit** the Test Menu now. Where **Index functions** will be needed later, click to the "Master Index" and the "Slave Index" boxes to execute the following tests:

- When you move the corresponding axis forward, you will find the number of encoder pulses between two index pulses in the display window. Where the index comes from the encoder itself, this is the ppr number of the encoder. Many times, when using external index pulses from a proximity, the accurate number of pulses between two markers is not exactly known and you can find it out by this test (see "N", "K" and "Factor1" in section 6. which is important for successful index operation!).
- When we move slow enough, we can also see the index pulses blinking in one of the indicator boxes (Upper = HTL-index, Lower = TTL-index).
- When we rotate to reverse direction, the display will not show our impulse number, but it's 16 bit complement which is "65536 - impulse number".

After performing the index tests, exit the test menu and get back to the main screen.

13.9 We must now adjust our **Gain Total** setting. This is to ensure the Slave drive receives the correct speed reference voltage for the speeds it should run.

Select the **Adjust** function of the **Tools** menu.

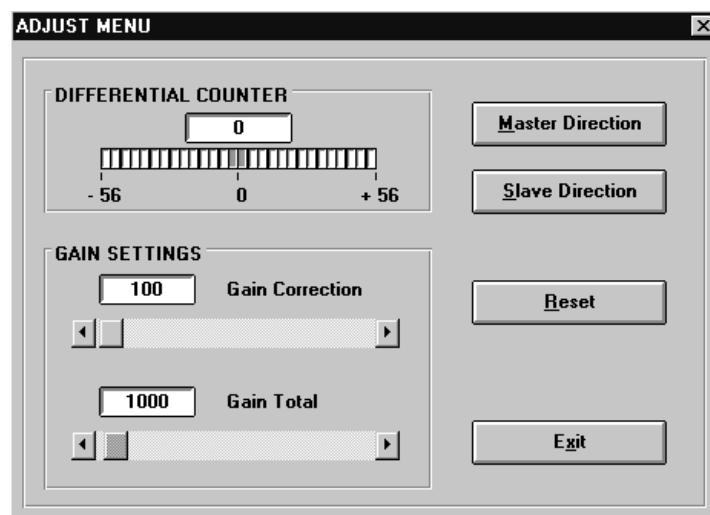

The subsequent procedure assumes our Gain Correction is set to 100 and you do not touch Gain correction before we have set Gain Total.

- Enable both, Master and Slave drive and run the Master **forward** at slow speed (e.g. 10-20% of max. speed). The Slave will follow the Master.
- Set the DIFFERENTIAL COUNTER to zero and the Colour bar graph to the green centre by switching Reset to ON.
- Watch the colour bar while you switch Reset OFF. It will deviate to right or left while the DIFFERENTIAL COUNTER counts to positive or negative. Please note, with very wrong initial setting we can swap over the opposite side after some time. Then please observe only to where we deviate immediately after releasing RESET.
- When we deviate to right (positive), our Gain Total setting is too low and must be increased.
- When we deviate to left (negative), our Gain Total setting is too high and must be reduced.
- Find the Gain Total setting that keeps the DIFFERENTIAL COUNTER around zero and the colour bar around the green centre zone.
- For rough adjusting, use the slide button in the Gain Total field. For fine tuning, use the ◀ ▶ keys.

13.10 When Gain Total is set to keep the bar around zero, we adjust **Gain Correction** now. The general rule is to increase the setting to values **as high as possible**, but still ensure stable operation. Typical settings are between 300 and 2000. Depending on drive, inertia and gearing you can get stability problems when Gain-Correction is too high (rough or noisy motion of the drive and visible oscillation of the bar graph and the differential counter). If so, reduce Gain Correction until we are stable again. When you have observed stability problems, you should also try to suddenly stop and restart the master and ensure the slave does not tend to oscillate after this action also. To change the Gain Correction settings use again the slide button and the ◀ ▶ keys like with Gain-Total.

13.11 Change the speed between standstill and maximum speed, observe the differential counter and the colour bar and **optimise** the Gain settings if necessary. Exit the ADJUST MENU when you feel your settings are o.k. This will automatically store your settings to the EEPROM of the BY125 synchroniser.

This concludes the general set-up procedure which needs to be done with every application. At this time your drives operate in a closed loop digital synchronisation and the next section will show you some hints how you could still improve performance with some applications.

14. Hints for Final Operation

14.1 Integrator

When, for stability reasons, you needed to keep your "Gain Correction" value low, any important non linearity in your drive system could cause changing phase errors* with changing speed (e.g. colour bar deviates to right at low speed, stays in centre at medium speed and deviates to left at maximum, speed).

* Please note that a deviation of the colour bar does not indicate a speed error at all, unless the differential counter shows figures outside a +/- 1024 error increment range. Inside this range, the speed always is error-free and deviations only refer to the constant number of encoder increments that the Master leads or lags the Slave position.

Where your differential counter remains in an acceptable range around zero (e.g. -5...0...+5) at any speed, there is no need to use the Integrator and you can leave the "Integration Time" at 000. Where you feel your phase accuracy should be better, set Integration Time to 50...40...30 20...10 or even lower. The Integrator will move the phase error always into a +/- 6 increments error window and the lower the setting, the faster the speed of compensation. Too low settings (= too high integration speeds) can result in oscillation, depending on individual inertia/friction/ dynamic conditions of your system.

With Index operation, the Integrator should be switched off, because the marker pulses will compensate phase errors.

14.2 Correction Divider

Where you find your colour bar oscillates quickly around zero over several fields, this indicates your encoder resolution is high with respect to mechanical clearance and backlash. Set the correction divider to 2 or 3 to get more stable operation.

14.3 Offset voltage

Some low cost AC inverter drives would have a dead band around zero. e.g. they would not respond to small speed references like 50mV. This can cause the slave to lag the Master with very low speed. You are free to use the Offset Correction register and set it to a negative value like "-50". This will result in a small positive output voltage like +50mV at standstill and the drive is kept at the threshold of it's dead band from where it can break off immediately.

14.4 Other settings

Up to now, we have operated in mode 1 with a couple of initial settings, in order to make commissioning easier. You are free now to set all variables to their final values, like required for your application.

14.5 It can be useful to observe the performance of synchronising by the oscilloscope function, which you can find in the **Tools** menu. You can record all the variables and registers by entering their serial access codes.

The following supplementary codes are available for readout and record:

:1	Synchronising error (Differential Counter)
:4	Integration register
:9	actual Master speed, scaled as "number of master increments per sampling time"

The following example shows the error register (channel 1) and the line speed (channel 2) while we accelerate the drives, and the peak shows how the unit corrected the position after an index check.

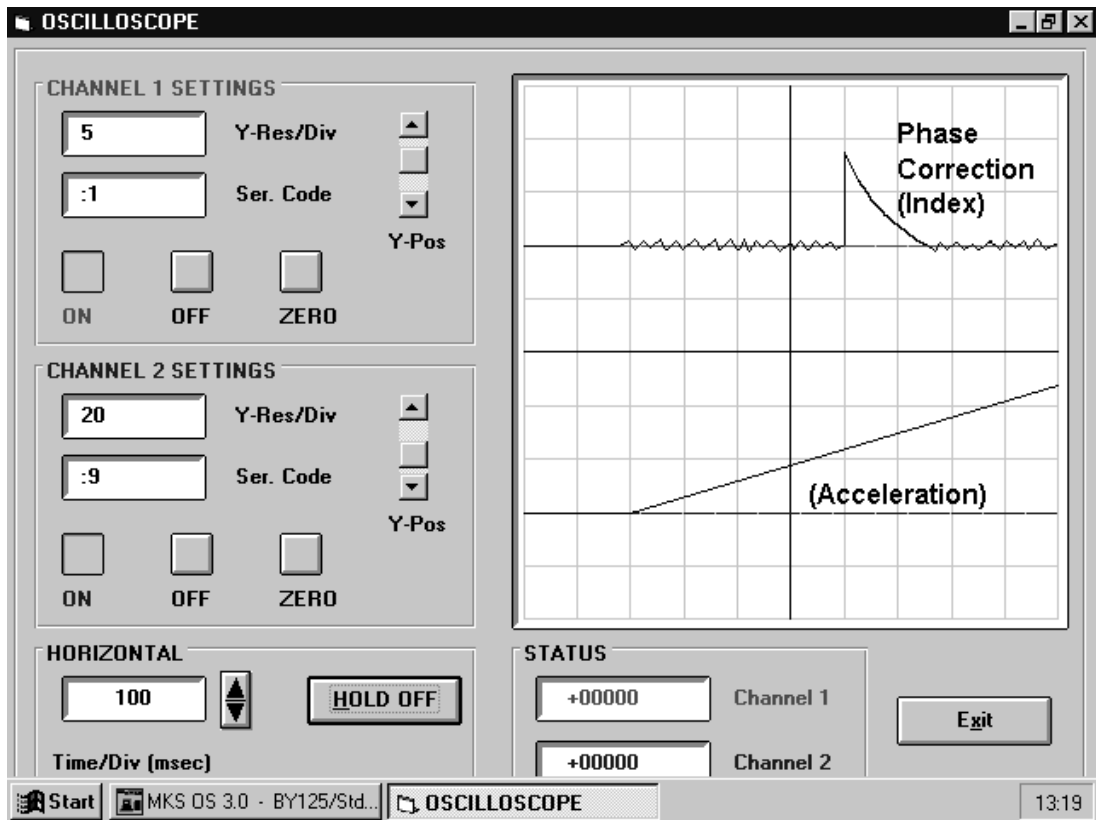

15. Serial Codes

Beside the serial access codes shown in this manual, the subsequent codes are available to execute the same commands that can be activated by the hardware inputs also:

Ser. access code	Bit of control word (C86)	Function	Type
60	7	Reset	S
61	6	Index Slave	S
62	5	Index Master	S
65	2	Trim -	S
66	1	Trim +	S
67	12	Activate Data	D
68	0	Store EEPROM	D

S = Static command, must be set to 1 to activate command and must be reset to 0 to deactivate command
D = Dynamic command, must be set to 1 to activate command. Is automatically reset to 0 after execution.

All commands can be activated either by its serial access code or by setting the corresponding bit of the **control word (Ser. Access code 86)**.

Please note that all serial commands are logical ORed to hardware commands (control inputs) and hence a command is ON whenever set by serial command or hardware input or both at a time.

The state of the control outputs can be read out by the **status word (Ser. Access code 85)** via serial interface. Bit 0, 1, 2 and 3 of the status word correspond to control outputs terminal 21, 22, 23 and 24.

For more details please refer to the manual of the Drivecom protocol which is available on request.

16. Master Reset and EEPROM Erasure

The unit carefully checks all entry data for validity and correctness within their permitted numeric range. If, as an extreme exception, invalid data should intrude into the register range, bad function or even a full hang-up could be the result. If this should ever happen

- Power down the unit and power up again after a few seconds.

This results in a complete reconfiguration of all ports and registers. **RAM and buffer data** will be **lost** and the unit restores all data from the EEPROM.

If, however, invalid data should have penetrated to the EEPROM, even the previous steps will not help. In this case:

- Switch off the unit
- Set all parallel command lines (screw terminals 5 to 10) to "High" at the same time.
- Power up the unit again and keep the command lines "High" for at least 500 ms.

This will clear up all the EEPROM to its minimum values, and all registers need to be set-up once more.

Above steps represent an emergency procedure that you will never have to apply under regular conditions. In an extreme case however (i. e. lightning-strike in the factory etc.) they could help to get the unit working again.

Please note it is a must to clear up the EEPROM whenever you have changed the processor chip for upgrade or modification of the firmware!

17. Dimensions and Specifications

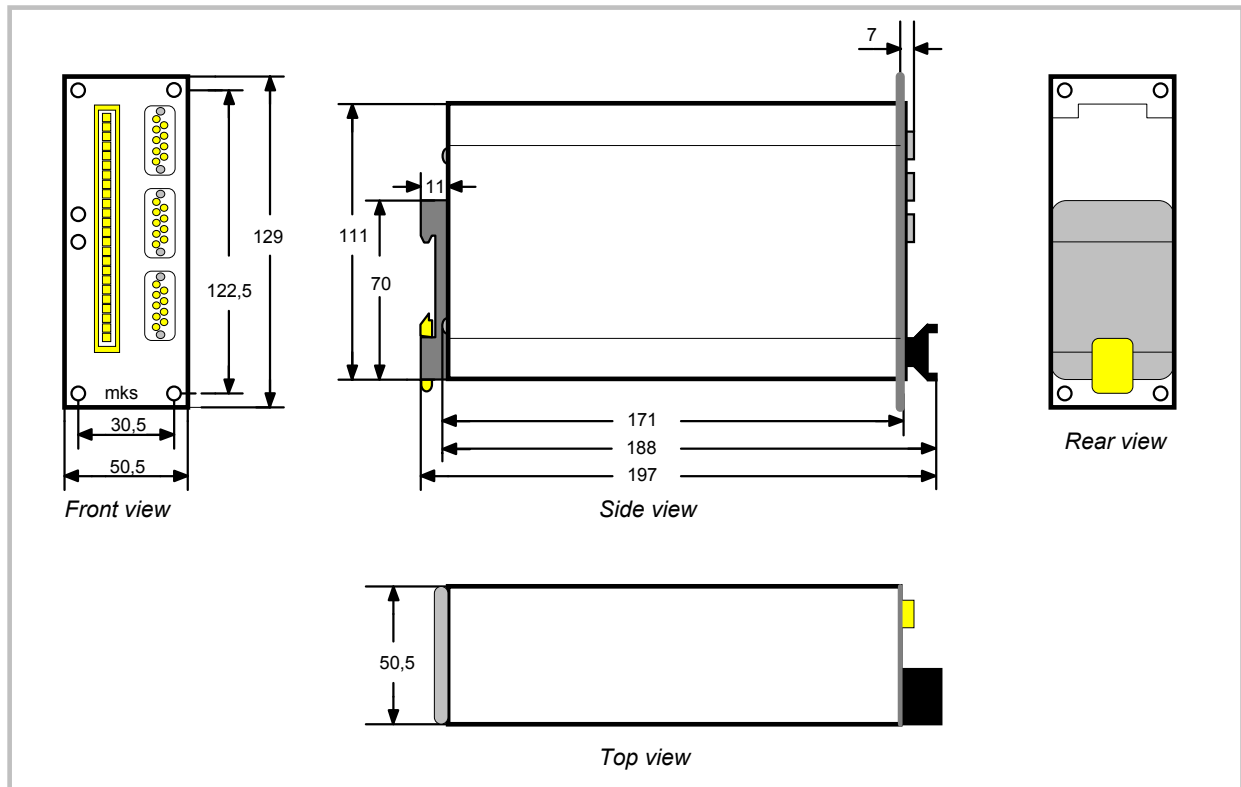

Power supply	:	18...30 V unstabilised
Consumption	:	approx. 200 mA (plus 25 % of the encoder supply currents, if internal encoder supply used)
Encoder Supply	:	Aux. voltage 5,5 V, max. 500 mA, not short-circuit proof
Processor	:	H8 / 325 with 20 MHz clock frequency
PBC and Technology	:	SMD, Multilayer PCBs, high-speed logic 74 HCT
Encoder Inputs	:	Two A, \bar{A} , B, \bar{B} , Z, \bar{Z} (5 V TTL / RS 422), $R_i = 1 \text{ k}\Omega$
Other Inputs	:	6 control lines, all PNP with 18 - 30 V level, $R_i = 15 \text{ k}\Omega$
Serial link	:	RS 232 with DTR output and (optional) RS 485
Absolute max. frequency	:	80 kHz
Response time	:	approx. 160 μs
Analogue IN / OUT	:	1 input + / - 10 V ($R_i = 100 \text{ k}\Omega$) 1 output + / - 10 V ($I_{\text{max}} = 5 \text{ mA}$) Resolution: 12 Bit (= 4096 steps)
Analogue Correction	:	10 Bit = 1024 error increments
Saturation of error memory	:	32 000 error increments
Control Outputs	:	4 transistor outputs (opto-coupler 50 V / 30 mA max)
Speed error	:	+ / - 0.00 (absolute)
Operating temperature	:	0...45° C
Dimensions	:	see drawing
Weight	:	approx. 850 g

18. Appendix: Option UP125

All previous remarks and hints are valid for drives accepting a +/- 10 volts speed input signal, where the direction of rotation depends on the polarity of the input voltage.

However, many of the standard AC inverter drives offer only a positive input range, and the direction of rotation is selected by means of two digital inputs (“Forward enable” and “Reverse enable”). The standard BY125 firmware will have a couple of problems to handle this type of drives under certain conditions. Therefore we offer a special firmware that takes into consideration the special features of 1-quadrant inverter drives. Where you intend to use such a drive as a Slave, please order

BY125 with Option UP125

and you will receive the same hardware, but with the special firmware (no difference in price). The subsequent comments describe the difference:

- 18.1 You must set register “LV-Calculation” to 5 (or to 6 where reciprocal characteristics should be required). With digital feed forward, the unit will generate only positive voltages at the analogue output, no matter if we move forward or reverse.
- 18.2 Output terminal 23 provides a “Forward” output and terminal 24 provides a “Reverse” output. The outputs switch to “HIGH” to select the corresponding direction. The outputs “Out of Sync” and “Index o.k.” are not available with this version.

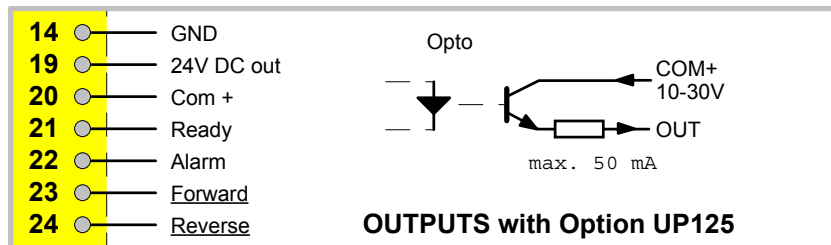

- 18.3 Connect your Slave drive to the BY125 as shown:

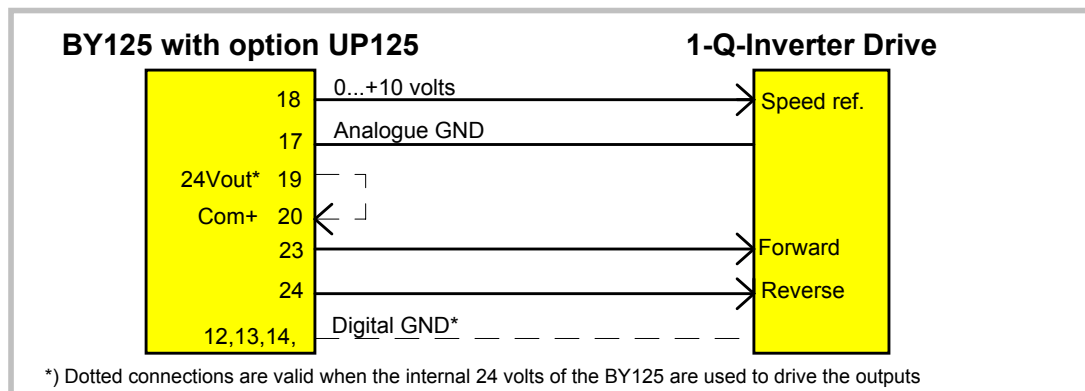

- 18.4 In the menu, instead of register “Index Window” you will find the register “**Dead Band**”. This register provides proper control of the Forward and Reverse direction outputs as follows:

- When the Master is moving into forward direction, the “Forward” output will be HIGH and the “Reverse” output will be LOW
- When the Master is moving into reverse direction, the “Reverse” output will be HIGH and the “Forward” output will be LOW
- When the Master is at Standstill, there are three options:
 - a) The relative position of the Slave is behind the Master (underswing situation). Then the “Forward” signal will remain on with a small voltage at the analogue output, so the Slave can crawl forward into the correct position
 - b) The relative position of the Slave is ahead of the Master (overswing situation). Then the “Reverse” signal will remain on with a small voltage at the analogue output, so the Slave can crawl reverse into the correct position
 - c) The relative position is inside the set window. Then both direction outputs will be off and the analogue output will be zero.

- With inverter drives, you must leave a +/- tolerance window where in standstill the relative Slave position is allowed to be without further actions of the controller. This window is set by the register “**Dead Band**”. The scaling is in “analogue increments” where each increment corresponds to 5 mV. A typical register setting would be 15 which means that both direction outputs remain OFF (drive disabled) as soon as the speed reference voltage gets lower than 75 mV.

Hint: Most of the inverter drives would have an analogue dead zone near zero, this means they would not start to move with small voltage, but only break off when we overpass a certain minimum threshold (i.e. 100 mV)

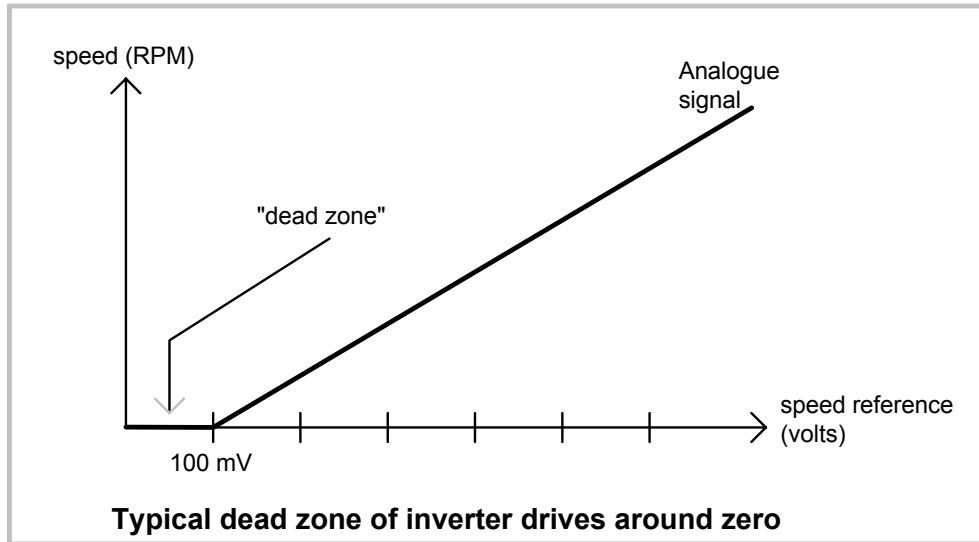

It is easy to understand that this kind of behaviour makes it difficult to have accurate control over the full speed range. For better performance we should therefore set an analogue offset of 100 mV (example), which, in standstill, keeps the drive already close to the break-off threshold and makes it move immediately with the first change of the analogue signal.

To do this, you can use register “Offset Correction” (C47). Every increment there corresponds to a voltage of 5 mV. Please note you must set the register to negative values to get positive voltage! Example: setting to -20 will result in a +100 mV output instead of zero.

Recommended procedure: (must be done before you run the Adjust menu to set the Gains)

- Make sure the master is in standstill. Click “Reset” to ON state, so our differential counter is held to zero. Enable the Slave drive by external signal (both BY125 direction outputs will be OFF at this time).
- Change register “Offset Correction” to values like -10, -11, -12 etc. until you observe that the drive breaks off to move. Then reduce the setting by one digit and store the new setting.

19. History

Version	Name	Date:	Page:	Changes / Supplements:
BY12512P	TJ	Sept. 03	12 18, 33 23 24 34 36	Encoder input options HTLIN1 and HTLIN2 Integrator must be switched off with index registration Only one LED on front side Serial access codes in fig. 22+23 corrected Serial access of control word and status word. Encoder supply, input resistance, response time